



CHIN-UP RACK

Μονόζυγο/Δίζυγο

(Οδηγίες Συναρμολόγησης | Assembly Instructions)

Οδηγίες
συναρμολόγησης
στη σελίδα 2

Assembly
instructions
on page 5

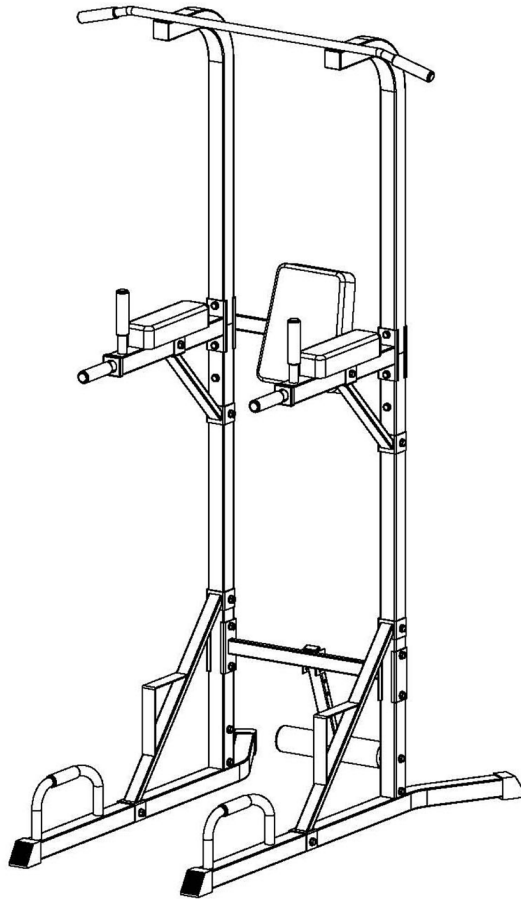

Μάθε περισσότερα
για το όργανο
σκανάροντας το QR

Learn more about the
chin-up rack by
scanning the QR

ITEM NO.: 44273







@amila.gr





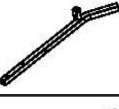

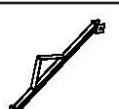
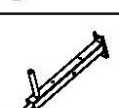
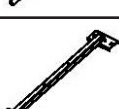
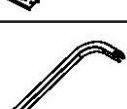
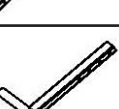
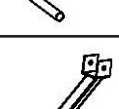

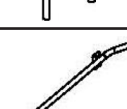
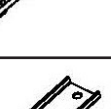
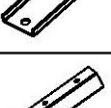

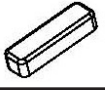







AMILASPORTS

WWW.AMILA.GR

ΛΙΣΤΑ ΕΞΑΡΤΗΜΑΤΩΝ

#	ΤΜΧ	ΠΕΡΙΓΡΑΦΗ	ΣΧΗΜΑ
A	1	Δεξί πόδι	
B	1	Αριστερό πόδι	
C	2	Κάθετος σωλήνας	
D	1	Οριζόντια αντηρίδα	
E	2	Διαγώνια αντηρίδα	
F	2	Αντηρίδα χεριών	
G	1	Αντηρίδα πλάτης	
H	2	Καμπύλος άνω σωλήνας	
I	1	Αντηρίδα με αφρώδη επικάλυψη	
J	2	Διαγώνια αντηρίδα II	
K	2	Στηρίγματα χεριών	
L	1	Μπάρα έλξης	
M	2	Πλάκα ένωσης	
N	2	Σωλήνας ένωσης	

#	ΤΜΧ	ΠΕΡΙΓΡΑΦΗ	ΣΧΗΜΑ
1	1	Μαξιλάρι πλάτης	
2	2	Μαξιλάρι χεριών	
3	4	Τετράγωνο καπάκι	
4	2	Πλαστική ροδέλα	
5	2	Τετράγωνο καπάκι 50*50	
6	1	Παραλληλόγραμο καπάκι 40*20	
7	8	Στρογγυλό καπάκι Ø25	
8	8	Αφρώδης χειρολαβή Ø25	
9	2	Αφρώδες κάλυμμα	
10	2	Πείρος	
11	2	Βίδα M8*40	
12	4	Βίδα M8*70	
13	4	Βίδα M10*20	
14	2	Βίδα M10*20	
15	6	Βίδα M10*65	
16	18	Βίδα M10*70	
17	6	Ροδέλα 8	
18	50	Ροδέλα 10	
19	2	Παξιμάδι ασφαλείας M10	
20	22	Παξιμάδι M10	

Βήμα 1

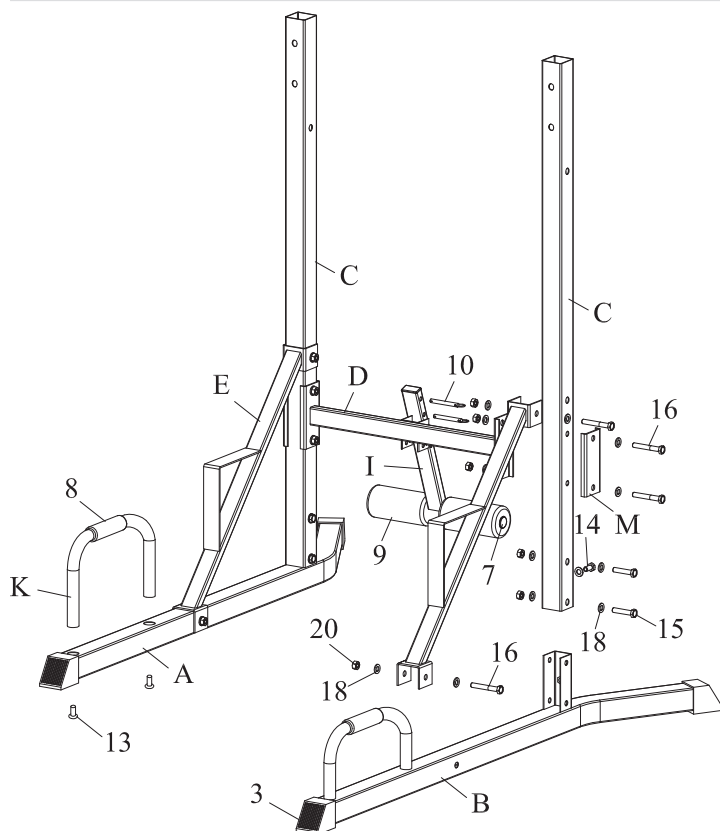

- Τοποθετήστε τα τετράγωνα καπάκια (3) στα δύο πόδια (A, B). Συνδέστε τα στηρίγματα χεριών (K) στα πόδια (A, B) με βίδες (13).
- Εισάγετε τους κάθετους σωλήνες (C) στα δύο πόδια (A, B) και σταθεροποιήστε τους με 2 βίδες M10*20 (14), 4 βίδες M10*65 (15), δέκα ροδέλες 10 (18) και 4 παξιμάδια M10 (20).
- Προσαρμόστε την οριζόντια αντηρίδα (D) και την πλάκα ένωσης (M) στους κάθετους σωλήνες (C) με 4 βίδες M10*70, ροδέλες 10 (18) και παξιμάδια M10 (20).
- Τοποθετήστε τις διαγώνιες αντηρίδες (E) στα πόδια (A, B) και κάθετους σωλήνες (C) με βίδες 4 M10*70 (16), ροδέλες 10 (18) και παξιμάδια M10 (20).
- Περάστε τα αφρώδη καλύμματα (9) στην αντίστοιχη αντηρίδα (I). Έπειτα συνδέστε την αντηρίδα (I) στην οριζόντια αντηρίδα (D) με 2 πείρους (10).

Βήμα 2

- Εισάγετε τον σωλήνα ένωσης (N) στους κάθετους σωλήνες (C) και στερεώστε με βίδες M10*65 (15), ροδέλες 10 (18) και παξιμάδια M10 (20).
- Βάλτε τα μαξιλάρια χεριών (2) στις αντηρίδες χεριών (F) με βίδες M8*70 (12) και ροδέλες 8 (17).
- Συνδέστε τις αντηρίδες χεριών (F) και αντηρίδα πλάτης (G) στους κάθετους σωλήνες (C) και καμπύλους άνω σωλήνες (H) με βίδες M10*70 (16), ροδέλες 10 (18) και παξιμάδια M10 (20).
- Προσαρμόστε τις διαγώνιες αντηρίδες II (J) στους κάθετους σωλήνες (C) και αντηρίδες χεριών (F) με βίδες M10*70 (16), ροδέλες 10 (18) και παξιμάδια M10 (20).
- Στερεώστε το μαξιλάρι πλάτης (1) στην αντηρίδα πλάτης (G) με βίδες M8*40 (11) και ροδέλες 8 (17).

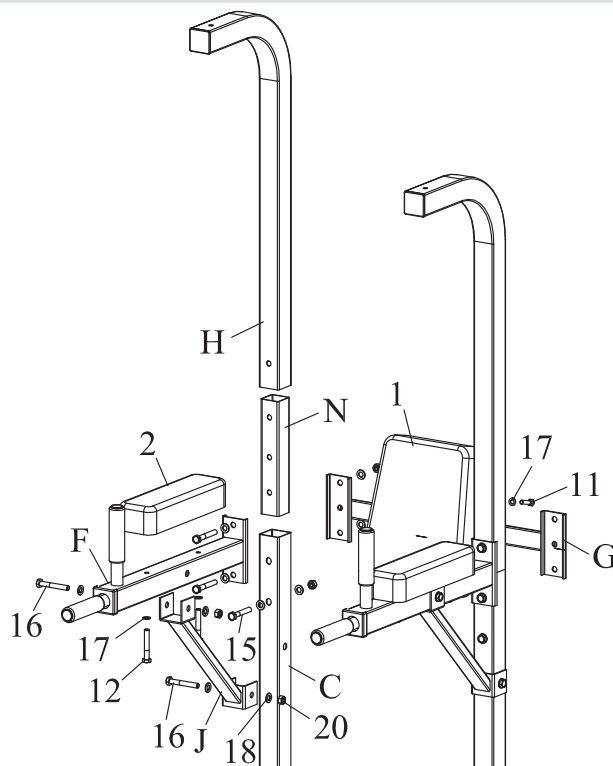

Βήμα 3

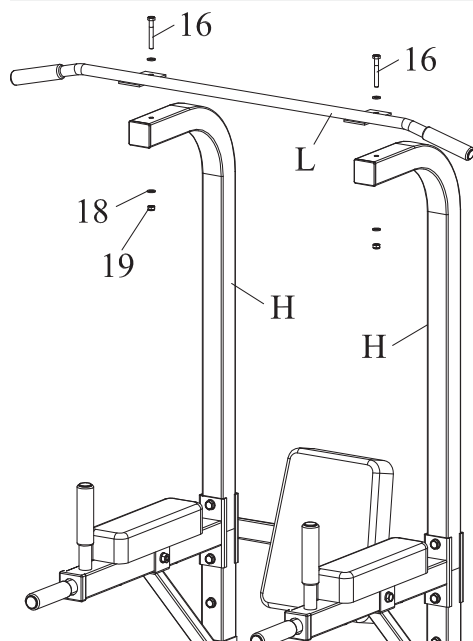

- Στερεώστε τη μπάρα έλξης (L) στους καμπύλους άνω σωλήνες (H) με βίδες M10*70 (16), ροδέλες 10 (18) και παξιμάδια ασφαλείας M10 (19).

ΑΣΚΗΣΕΙΣ



Κοιλιακοί



Έλξεις



Βυθίσματα τρικεφάλων







Πους-απς





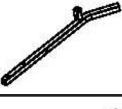
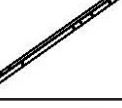

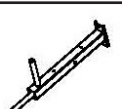
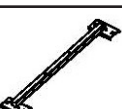
Κοιλιακοί

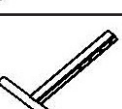
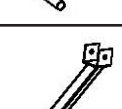
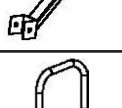
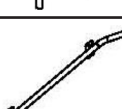
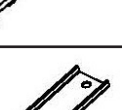
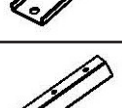
PARTS LIST

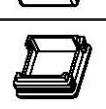
EN

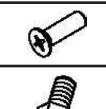
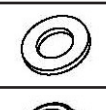
#	PCS	DESCRIPTION	DRAWING
A	1	Right beam	
B	1	Left beam	
C	2	Down post	
D	1	Horizontal support	
E	2	Diagonal support	
F	2	Armrest support	
G	1	Backrest support	
H	2	Up post	
I	1	Foam support	
J	2	Diagonal support II	
K	2	Handle support	
L	1	Pull bar	
M	2	Joint plate	
N	2	Joint tube	

#	PCS	DESCRIPTION	DRAWING
1	1	Back rest	
2	2	Arm rest	
3	4	Square end cap	
4	2	Plastic bushing	
5	2	Square cap 50*50	
6	1	Rectangular cap 40*20	
7	8	Round cap Ø25	
8	8	Handle foam Ø25	
9	2	Foam roller	
10	2	Pin	
11	2	Bolt M8*40	
12	4	Bolt M8*70	
13	4	Bolt M10*20	
14	2	Bolt M10*20	
15	6	Bolt M10*65	
16	18	Bolt M10*70	
17	6	Washer 8	
18	50	Washer 10	
19	2	M10 Lock nut	
20	22	M10 Nut	

Step 1

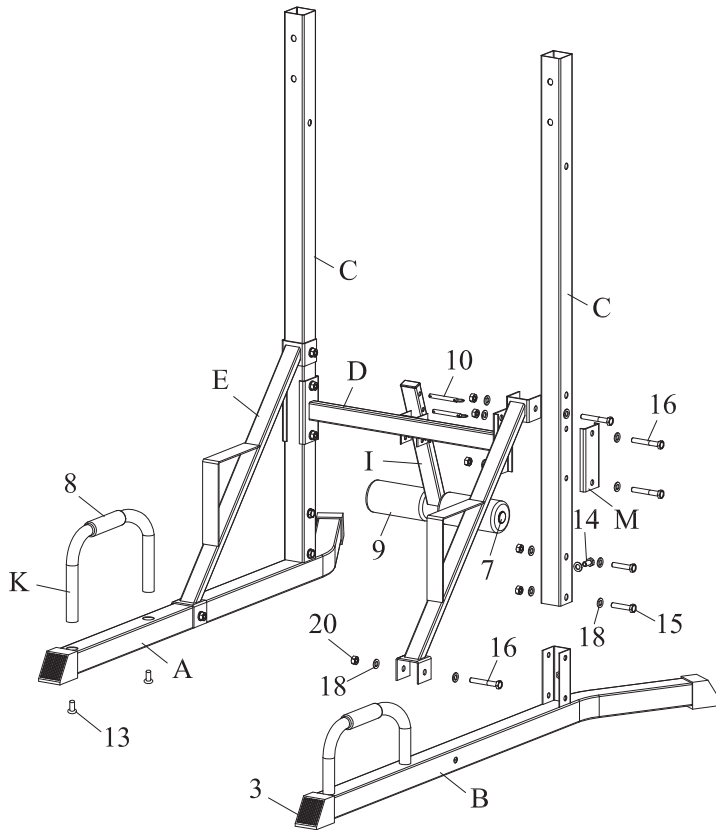

- Attach square end caps (3) to right beam (A) and left beam (B). Attach handle support (K) to left beam (A) and right beam (B) with cross head bolt M10*20 (13).
- Slide down posts (C) onto right beam (A) and left beam (B), screw with two bolts M10*20 (14), four bolts M10*65 (15), ten washers 10 (18) and four nuts M10 (20).
- Attach horizontal support (D) and joint plate (M) to down posts (C) with four bolts M10*70 (16) and washers 10 (18) and nuts M10 (20).
- Attach diagonal support (E) to right beam (A) and down post (C) with two bolts M10*70 (16) and washers 10 (18) and nuts M10 (20).
- Attach diagonal support (E) to left beam (B) and down post (C) with two bolts M10*70 (16) and washers 10 (18) and nuts M10 (20).
- Slide foam rollers (9) onto foam support (I).
- Attach foam support (I) to horizontal support (D) with two pin (10).

Step 2

- Insert joint tube (N) into down posts (C), screw with bolt M10*65 (15) and washers 10 (18) and nuts M10 (20).
- Attach arm rests (2) to arm rest supports (F) with bolts M8*70 (12) and washers 8 (17).
- Attach arm rest supports (F) and back rest support (G) to down post (C) and up post (H) with bolts M10*70 (16) and washers 10 (18) and nuts M10 (20).
- Attach diagonal support II (J) to down posts (C) and arm rest support (F) with bolts M10*70 (16) and washers 10 (18) and nuts M10 (20).
- Attach back rest (1) to back rest support (G) with bolts M8*40 (11) and washers 8 (17).

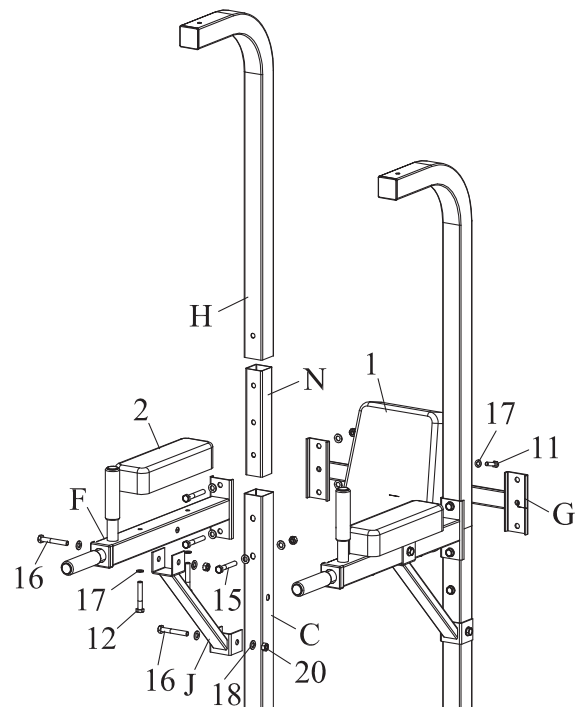

Step 3

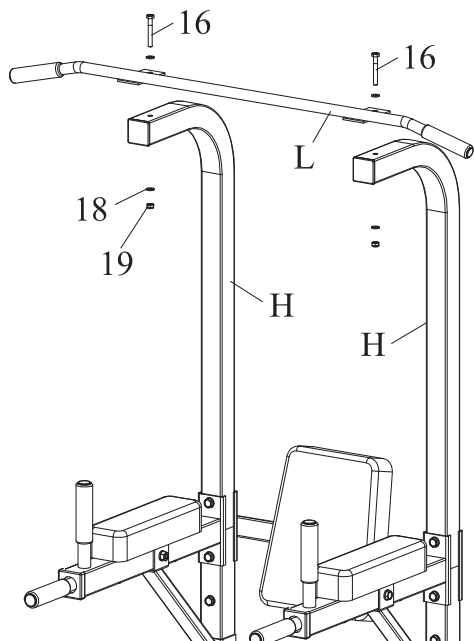

- Attach pull bar (L) to up posts (H), screw with bolts M10*70 (16) and washers 10 (18) and lock nuts M10 (19).

EXERCISES



Abdominals



Pull-ups



Tricep dips



Push-ups



Abdominals

ELDICO[™]
sport



in conformity with the
alternative packing
management system

Διανέμεται από την **ΕΛΔΙΚΟ ΣΠΟΡ ΜΟΝ. Α.Ε.Ε.**

Distributed by **ELDICO SPORT SA**

eMail: support@eldico.gr • Web Site: eldico.gr