

DESCRIPTION: ReNegaDE Air Mag. M.W. 叁
CODE: 702021
VERSION: 20211007

ReNegaDE M.W. 叁

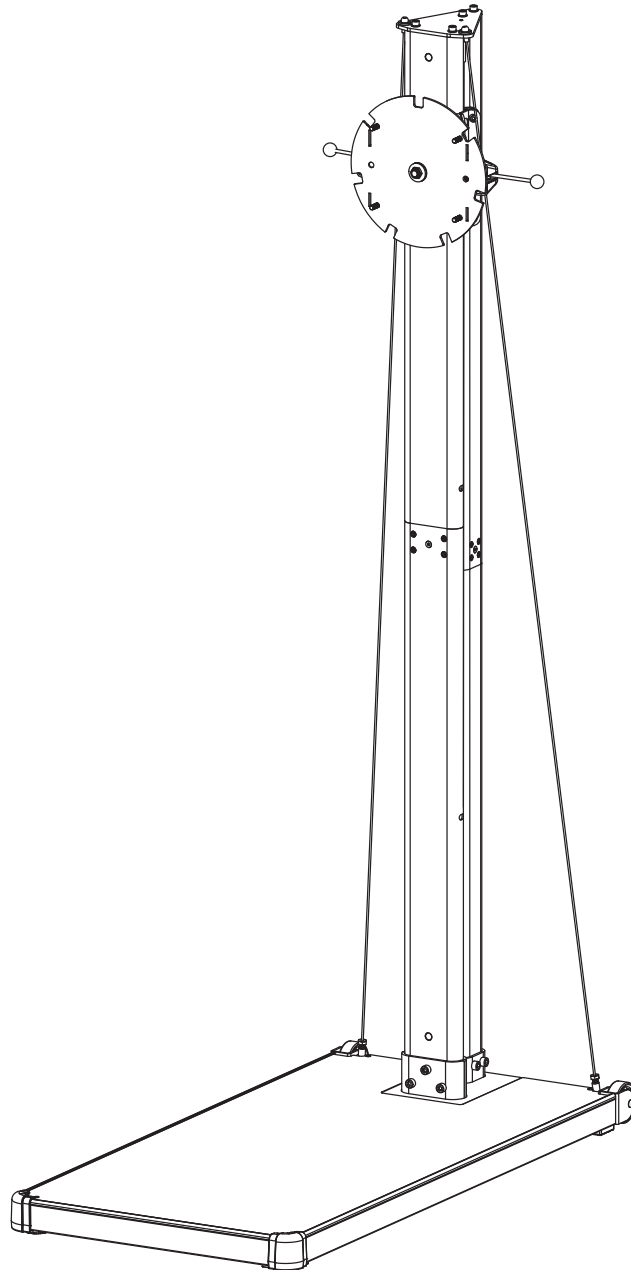

**PLEASE READ THIS INSTRUCTION MANUAL
BEFORE YOU BEGIN ASSEMBLY**

INSTRUCTION MANUAL

contents

safety information	03
customer support	04
assembly instructions	05
how to take care of your air mag. m.w. III	12
troubleshooting	12
air mag. m.w. III features explained	13
exercising with your air mag. m.w. III	16
exploded diagrams and parts list	22
your warranty	24

Safety Information

PLEASE READ THIS INSTRUCTION MANUAL BEFORE YOU BEGIN ASSEMBLY. GREAT CARE HAS BEEN TAKEN TO DESIGN THESE INSTRUCTIONS AND FOLLOWING THEM WILL HELP YOU WITH QUICKER ASSEMBLY AND MINIMISE THE RISK OF INJURY

YOU ARE RESPONSIBLE FOR YOUR OWN SAFETY - THIS LIST IS NOT EXHAUSTIVE.

- Always assemble and operate the product on a level surface, ensure that the product is stable before use.
- Try to ensure that your back is straight while exercising, especially for long periods
- The safety level of this equipment can only be maintained if it is regularly examined for wear and tear
- Keep hands away from moving parts.
- Replace defective components immediately, and/or keep the equipment out of use until it is repaired.
- Use only the adjustment settings as described in the instructions. Always use the correct adjustment pin/fixing.
- Special attention should be taken to inspect the components, such as pulleys, bearings, straps, rollers are always more susceptible to wear before use.
- Never leave any adjustment devices projecting from the product.
- Always wear suitable clothing and footwear e.g. tracksuit / shorts / training shoes
- Remove all personal jewellery before exercising.
- Ensure you warm-up well before using the equipment as this will help to prevent muscle strain.
- After eating, allow 1-2 hours before exercising as this will help to prevent muscle strain.
- Never overload the equipment – the maximum user weight of this ski is 180kg / 400lbs.
- Don't rock this equipment from side to side
- Never use the equipment in any other manner other than the ways explained in these instructions and/or any wall-chart supplied.
- This product has an intergrated resistance system without a constant power mode that is governed by magnetic resistance.
- Losing grip or suddenly releasing the handle could result in an uncontrolled return, ensure there is free space around the product.
- You may want to store this product away to save space - be aware of moving mechanical parts which could cause injury.
- To prevent shock, keep all electical components, such as the console, motor, cord and switch away from water.
- Do not use any accessories that aren't specifically recommended by the manufacturer, these might cause injuries or cause the unit to fail.
- Work within your recommended exercise level, do **NOT** work to exhaustion.
- If you feel any pain or abnormal symptoms, **STOP YOUR WORKOUT IMMEDIATELY**. Consult your physician immediately.
- Parents and others in charge of children should be aware of their responsibility, because the natural play instinct and the fondness of experimenting of children can lead to situations and behaviour for which the training equipment is not intended
- If children are allowed to use the equipment, their mental and physical development and above all their temperament should be taken into account. They should be controlled and instructed in the correct use of the equipment.
- The equipment is under no circumstances suitable as a children's toy.
- This appliance is not intended for use by persons (including children) with reduced physical, sensory or mental capabilities, or lack of experience and knowledge, unless they have been given supervision or instruction concerning use of the appliance by a person responsible for their safety.
- **The free area shall be not less than 0.6 m greater than the training area in the directions from which the equipment is accessed.**

! Injuries to health may result from incorrect or excessive training.

! Heart Rate Monitoring System may be inaccurate, Over exercise may result in serious injury or death. If you feel faint stop exercising immediately !

! Be aware of the edges on the platform when in use or move it around.

! The safety maximum length of the pulling handle motion on this product is 200cm, please be awared to avoid any exercise that over this motion range limit.

! The max. operating force allowed is 18 kg.

! It is your responsibility to contact us for further advices, when you found any damages which impact the original design and potential issue caused on the product after carton opened.

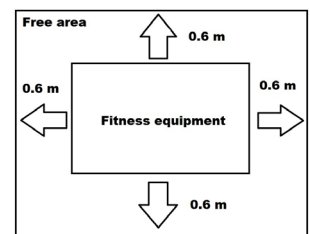

Safety Standards

This Air Mag. M.W. meets the requirements of the EN ISO 20957-1: 2013, Class SA

This product is not suitable for therapeutic purposes.

! It is important that you keep these instructions for future reference.

Care & Maintenance

- Always place the equipment in a dry environment.
- Use a warm, damp cloth to keep the product clean.
- No wet cleaning of electrical components, unplug before any care and maintenance
- The safety level of the equipment can be maintained only if it is regularly examined for damage and wear. This includes any straps, pulleys, nuts, bolts, moving parts, bushes, cords, wheels, bearings & connection points etc
- Ensure that you inspect the product regularly - at least once a week is recommended.
- Ensure that all fixings are tight before use.
- Always replace damaged / worn components with original parts from the manufacturer.

Protect the environment by not disposing of this product with household waste. Check your local authority for recycling advice and facilities (Europe only).



- This appliance is not intended for use by persons (including children) with reduced physical, sensory or mental capabilities, or lack of experience and knowledge, unless they have been given supervision or instruction concerning use of the appliance by a person responsible for their safety.
- Children should be supervised to ensure that they do not play with the appliance.
- Non-rechargeable batteries are not to be recharged.
- Rechargeable batteries are to be removed from the appliance before being charged.
- Different types of batteries or new and used batteries are not to be mixed.
- Batteries are to be inserted with the correct polarity.
- Exhausted batteries are to be removed from the appliance and safely disposed of
- If the appliance is to be stored unused for a long period, the batteries should be removed.
- The supply terminals are not to be short-circuited.
- This Air Mag. M.W. III comes up with dimensions of 129 x 61 x 216cm and 83.5 kg (184 lbs) weight.

Customer Support

Should you require any assistance regarding this product please gather the following information, and then contact us using the details below:

1. **Serial no.** - this can be found on the sticker below, located as indicated. For future reference, please write down your serial number in the space provided below.
2. **Original purchase date**
3. **Place of purchase**
4. **Information about the place and conditions of use**
5. **Precise description of the issue/defect**

Your Serial No. is:

Contact Us

Batch NO.:

702021/21/10

MADE IN TAIWAN

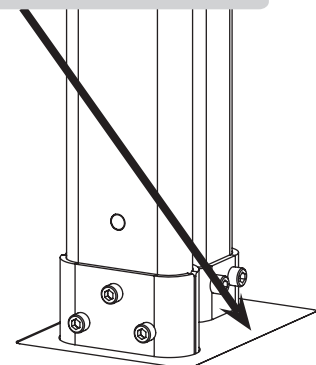

Assembly Instruction

Before you start

- 1. Prepare your work area -**
It is important for you to assemble the product at a clean and uncluttered space.
- 2. Work with a friend -**
we recommend you to have someone assisting you with the assembly as some of the components are quite heavy.
- 3. Open the carton -**
checking any warnings on the carton and make sure you have it the right way up.
- 4. Unpack the carton**
Make sure you have the following parts:

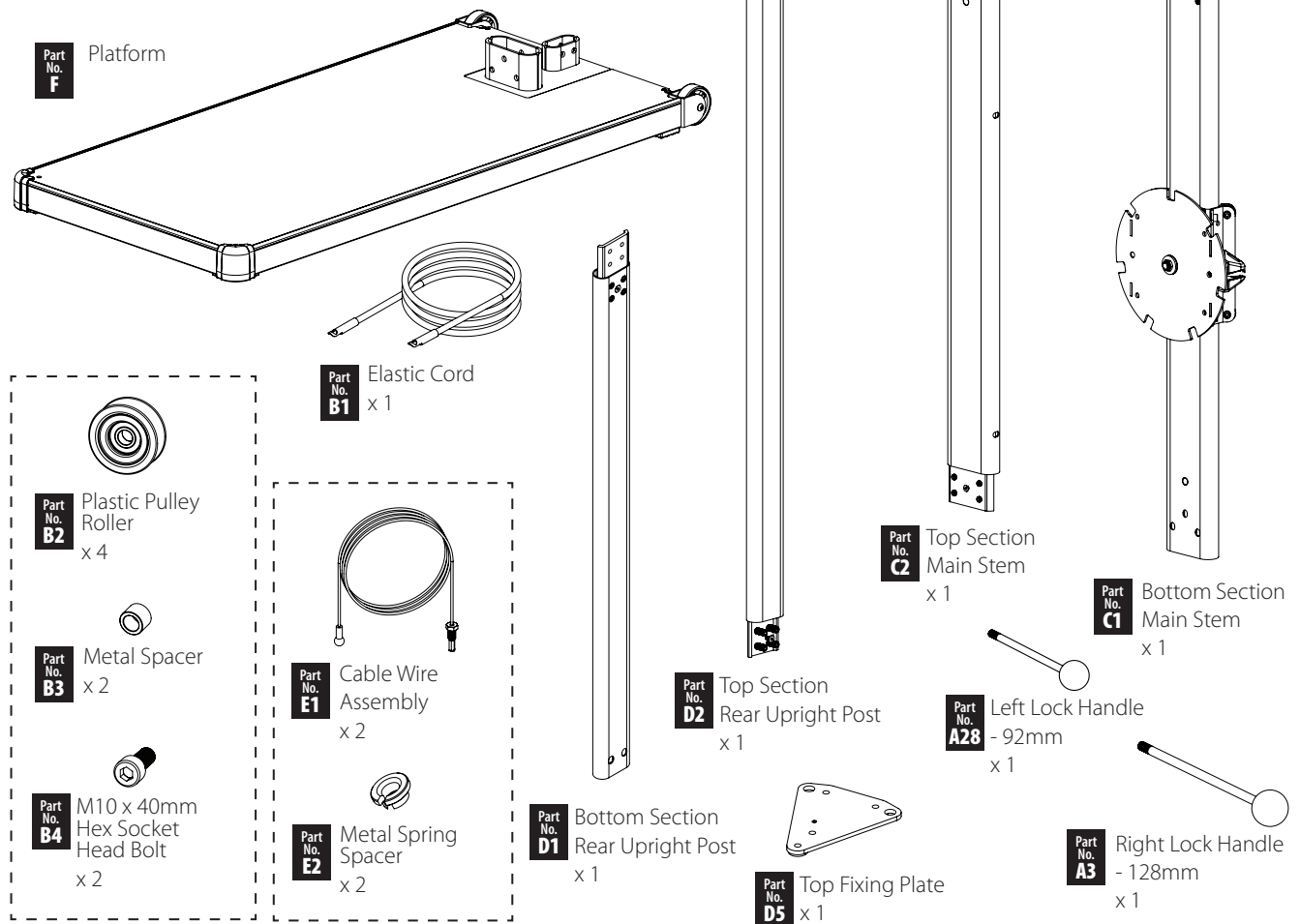

Fixings

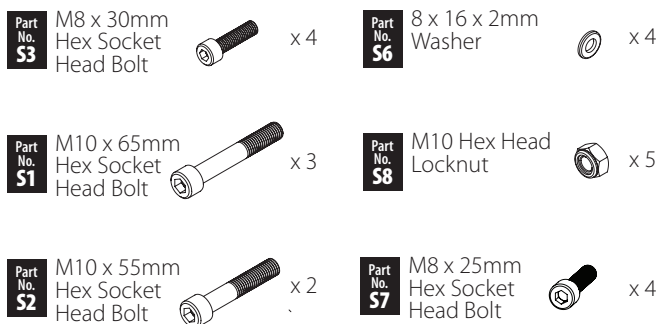

Tools and Consumables

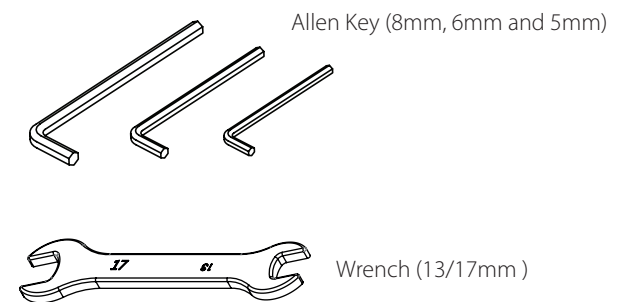

! This Air Mag. M.W. III takes up a floor space of 129cm x 61 cm for use, and weighs 83.5kg

! If you suspect you may have some parts missing, please contact us before going back to your retailer. Refer to the Customer Support section on page 4 for contact details.

1. Attach the Main Stem Assembly

1-1 Attach the Bottom Section Main Stem

- Attach the **Bottom Section Main Stem (C1)** to the mounting bracket carefully with three **M10 x 65mm Hex Socket Head Bolts (S1)** & **M10 Hex Head Locknuts (S8)** with finger tight in position firstly.

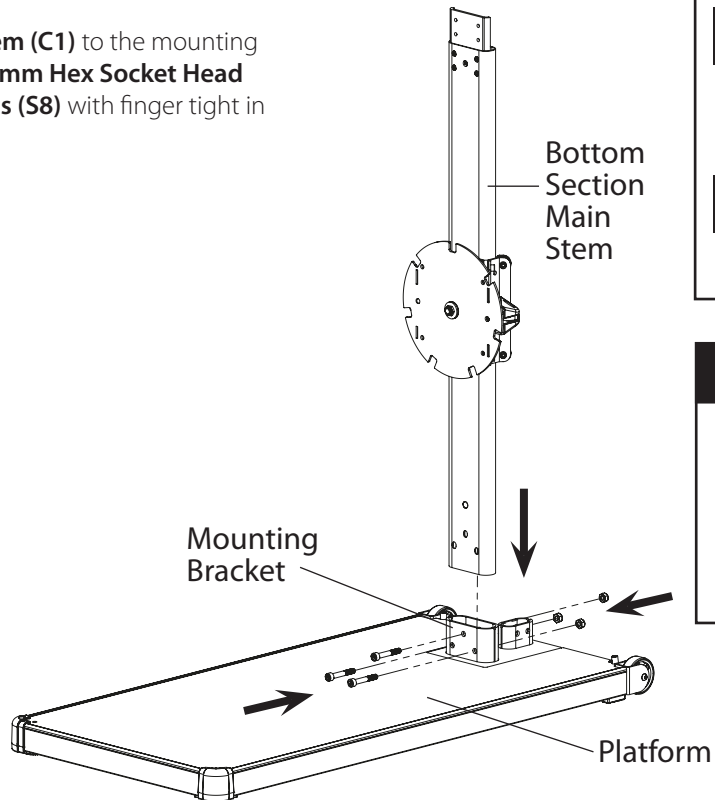

FIXINGS:

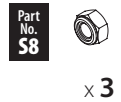
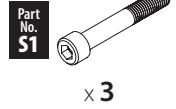

TOOLS:

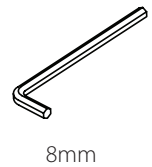

1-2 Attach the bottom Pulley Rollers

- Attach two **Plastic Pulley Rollers (B2)** & **Metal Spacer (B3)** onto the back of the **Bottom Section Main Stem (C1)** with **M10 x 40mm Hex Socket Head Bolt (B4)** in the same order as the diagram shown.
- Tighten the bolt securely with the 8mm Allen Key - provided.

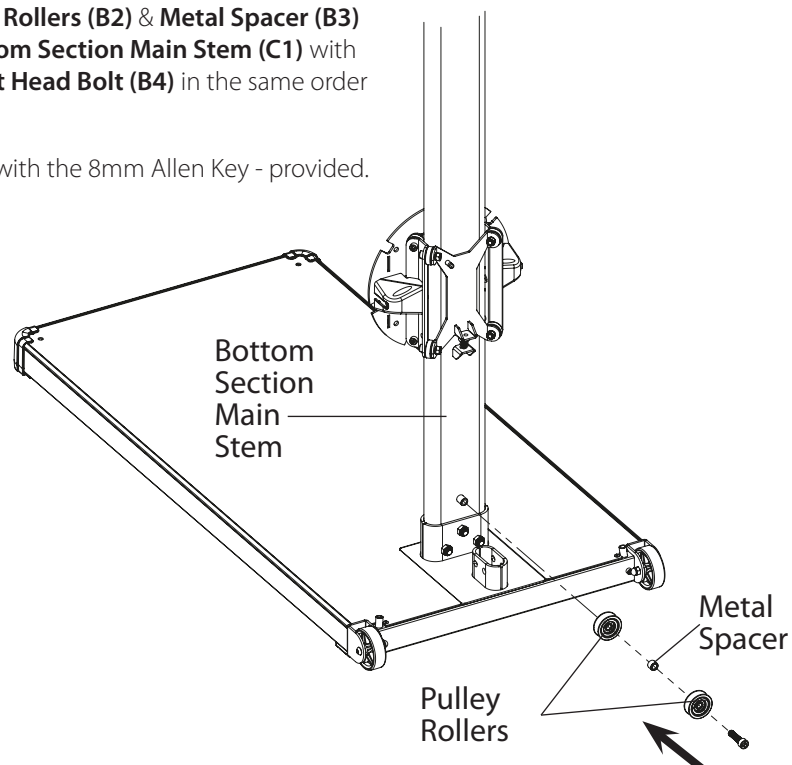

FIXINGS:

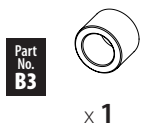
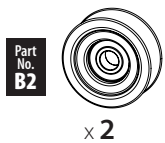

TOOLS:



1-3 Attach the top Pulley Rollers

- Attach two **Plastic Pulley Rollers (B2)** & **Metal Spacer (B3)** onto the **back of the Top Section Main Stem (C2)** with **M10 x 40mm Hex Socket Head Bolt (B4)** in the same order as the diagram shown.
- Tighten the bolt securely with the 8mm Allen Key - provided.

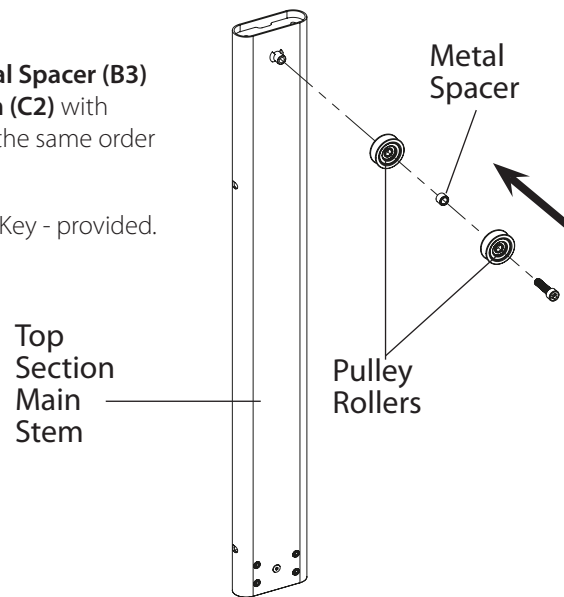

FIXINGS:

Part No. B2		x 2
Part No. B3		x 1
Part No. B4		x 1

TOOLS:

	8mm
--	-----

1-4 Attach the Top Section Main Stem

- Loosen four **M10 x 35mm Socket Set Screws (C8)** attached on the **Bottom Section Main Stem** 3 ~ 4 threads with provided 5 mm Allen Key carefully.
- Loosen four **M10 x 35mm Socket Set Screws (C8)** attached on the **Top Section Main Stem** 3 ~ 4 threads with provided 5 mm Allen Key carefully.
- Attach the **Top Section Main Stem (C2)** to the **Bottom Section Main Stem (C1)** evenly and tighten the **M10 x 35mm Socket Set Screws (C8)** lose on both section main stems securely with the 5 mm Allen Key – provided.

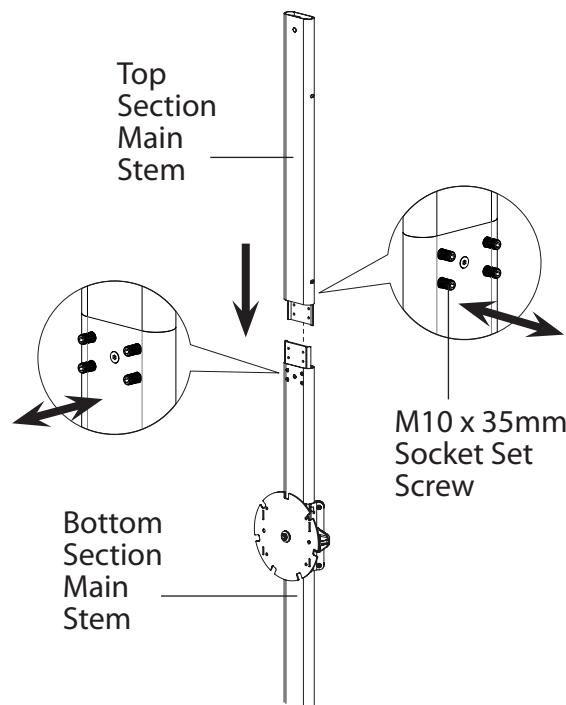

FIXINGS:

Part No. C8		x 8
--------------------	--	-----

TOOLS:

	5mm
--	-----

! Make sure the bolts are fully tightened evenly with the allen key.

1-5 Attach the Lock Handles

- Attach **Right Lock Handles (A3)** onto the **Rear Carriage Assembly** and secure by clockwise tighten as the diagram shown.
- Attach **Left Lock Handles (A28)** onto the **Rear Carriage Assembly** and secure by clockwise tighten as the diagram shown.

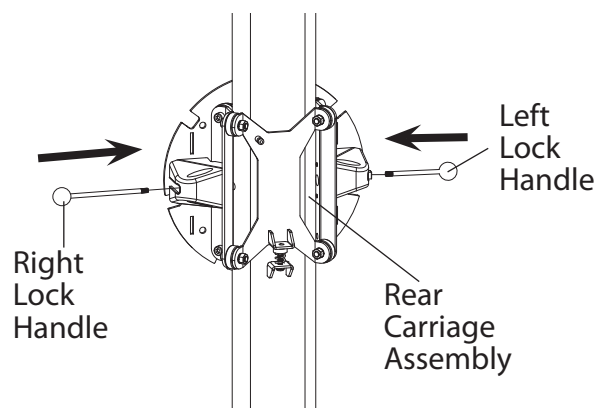

2. Attach the Rear Upright Post Assembly

2-1 Attach the Bottom Section Rear Upright Post.

- Attach the **Bottom Section Rear Upright Post (D1)** to the mounting bracket carefully with two **M10 x 55mm Hex Socket Head Bolts (S2)** & **M10 Hex Head Locknuts (S8)** with finger tight in position firstly.

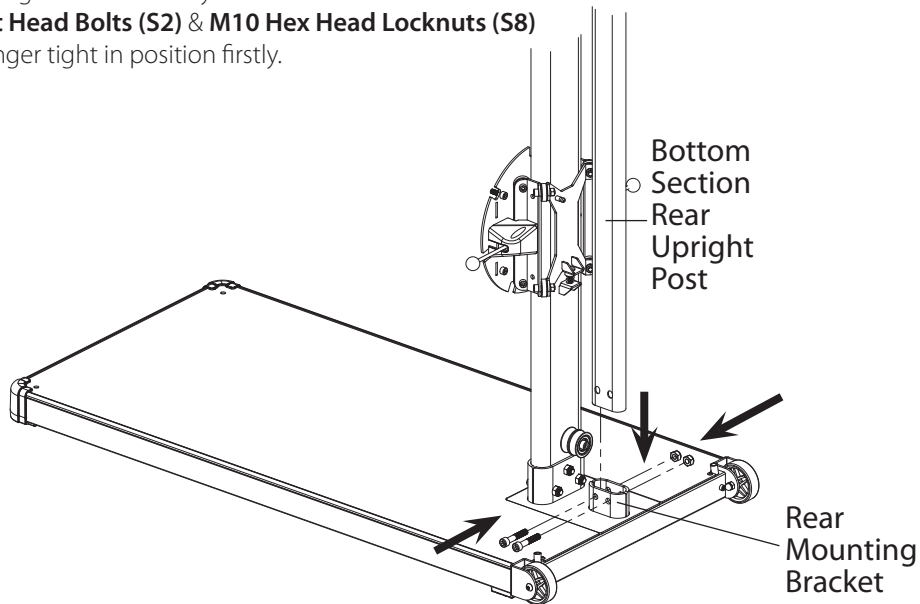

FIXINGS:

Part No. S2

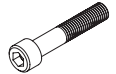

x 2

Part No. S8



x 2

TOOLS:

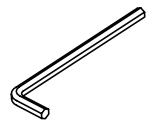

8mm

2-2. Attach the Top Section Rear Upright Post

- Loosen four **M10 x 25mm Socket Set Screws (D4)** attached on the **Bottom Section Rear Upright Post** 3 ~ 4 threads with provided 5 mm Allen Key carefully.
- Loosen four **M10 x 25mm Socket Set Screws (D4)** attached on the **Top Section Rear Upright Post** 3 ~ 4 threads with provided 5 mm Allen Key carefully.
- Attach the **Top Section Rear Upright Post (D2)** to the **Bottom Section Rear Upright Post (D1)** evenly and tighten the **M10 x 25mm Socket Set Screws (D4)** lose on both section rear upright posts securely with the 5 mm Allen Key – provided.

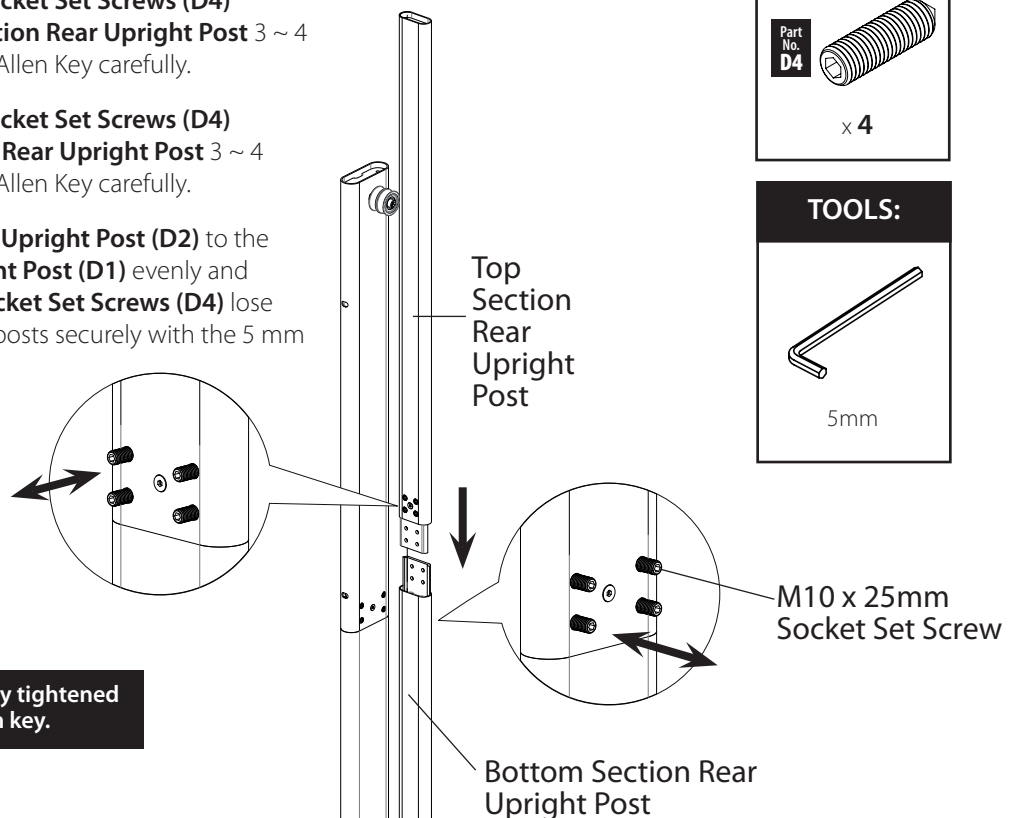

FIXINGS:

Part No. D4

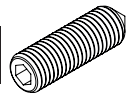

x 4

TOOLS:

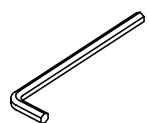

5mm

M10 x 25mm Socket Set Screw

Make sure the bolts are fully tightened evenly with the allen key.

3. Attach the Side Cable Wires Assembly

3-1 Attach the Top Fixing Plate

- Slide the **Cable Wire Ball End (E1)** through the fixing hole on the **Top Fixing Plate (D5)** and insert the **Metal Spring Spacer (E2)** onto the cable wire and engage it into the fixing hole securely as diagram shown carefully.
- Pull the Cable Wire downward to locate the **Cable Ball End** with **Metal Spring Spacer** in position properly.
- Repeat the same procedures for the other Cable Wire attachment.
- Attach the **Top Fixing Plate (D5)** to the **Top Section Main Stem (C2)** and **Top Section Rear Upright Post (D2)** evenly with four **M8 x 30mm Hex Socket Head Bolts (S3)** and **8mm x 16mm x 2 mm Washers (S6)** in the same order as the diagram shown.
- Tighten the bolts securely with the 6mm Allen Key - provided.

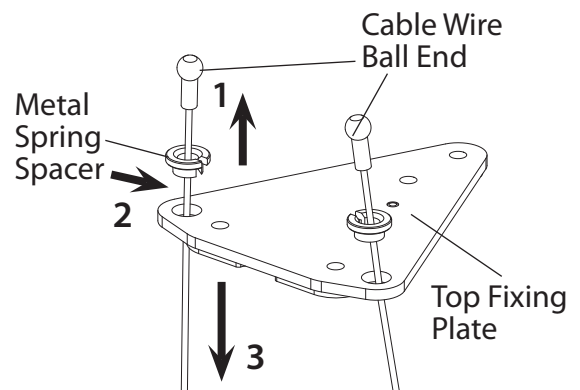



3-2 Attach the Side Cable Wires

- Pull the **Cable Wire (E1)** straight and thread the **M10 x 16mm Cable Wire Bolt** to the **Metal Sleeve (F8)** on the front edge of **Standing Platform (F1)** as shown
- Repeat the same procedures for the other Cable Wire Attachment.
- Tighten the bolts evenly to keep the **Main Stem & Rear Upright Post** straight and securely with the #13/17 Wrench – provided.

Try to feel the tension of two cable wires to ensure IF they are tighten.

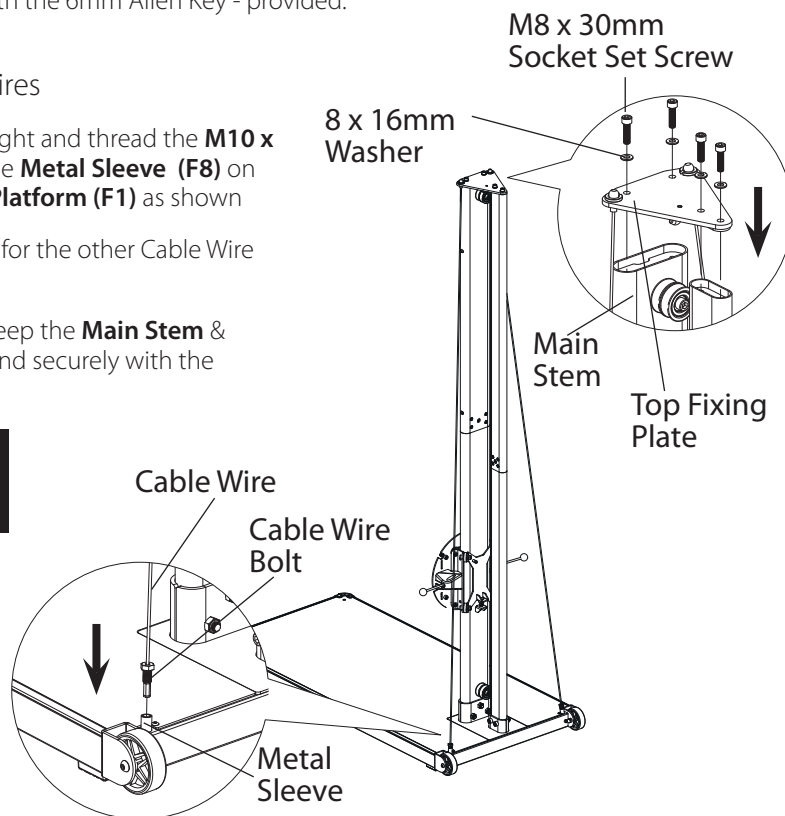
Ensure that the threads are engaged to a depth of 4 / 5 Cable Wire Bolt threads at least.

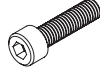

FIXINGS:	
Part No. S3	
	x 4
Part No. S6	
	x 4

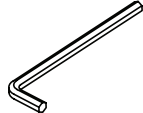
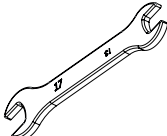
TOOLS:	
	8mm
	#13/17

3-3 Tighten all of the bolts & screws securely

- Tighten three **M10 x 65mm Hex Socket Head Bolts (S1)** & **M10 Hex Head Locknuts (S8)** on the **Main Stem Mounting Bracket** securely with 8mm Allen Key & 13/ 17 Wrench.
- Tighten two **M10 x 55mm Hex Socket Head Bolts (S2)** & **M10 Hex Head Locknuts (S8)** on the **Rear Upright Post Mounting Bracket** securely with 8mm Allen Key & 13/ 17 Wrench.

Make sure the bolts are fully tightened with the allen key & wrench.

4. Attach the Air Mag M.W.

4-1. Remove the metal posts from the back of the Air Mag. M.W.

- Loosen the four **M8 x 60mm Hex Socket Head Bolts** from the two metal posts as shown.

Note: The four Hex Socket Head Bolts, four Plastic Spacers and the two Metal Posts are used for packaging protection purpose, which won't be used again during the assembly.

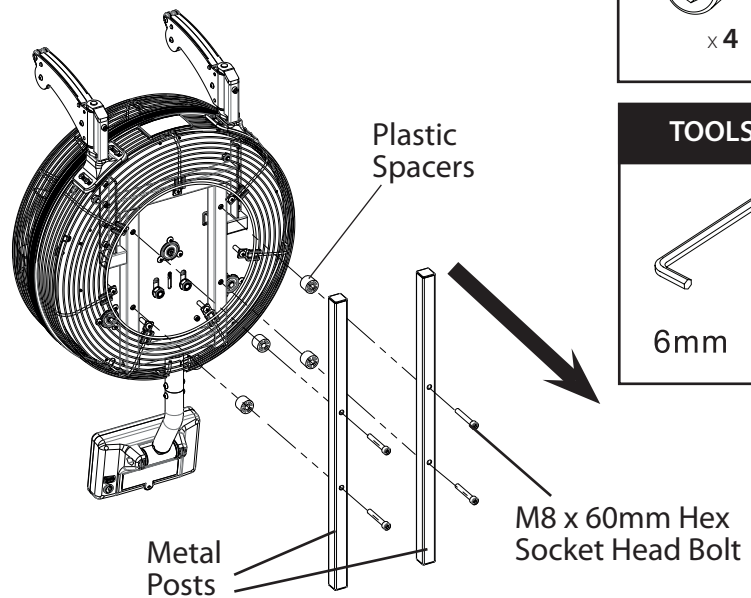

FIXINGS:



x 4

TOOLS:

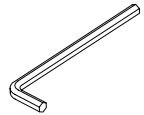

6mm

4-2. Attach the Air Mag. M.W.

- Check and ensure the **Rear Carriage Assembly** is located in bottom position of main stem.
- Have someone to assist you to hold the **Air Mag M.W.** evenly and attach it to the **Fixing Bracket** of the selected attachment with four **M8 X 25mm Hex Head Socket Bolts (S7)** as shown.
- Tighten the bolts securely with the 6mm Allen Key - provided.
- Pull the **Right Lock Handle (A3)** and raise the **Air Mag. M.W.** up to the top position of main stem and engaged.

Be sure to fit the parts in the same order as the diagrams shown.

Make sure the bolts are fully tightened evenly with the allen key.

The Air Mag. M.W. is heavy !! Please Take Care while raising it upward and moving it downward on main stem.

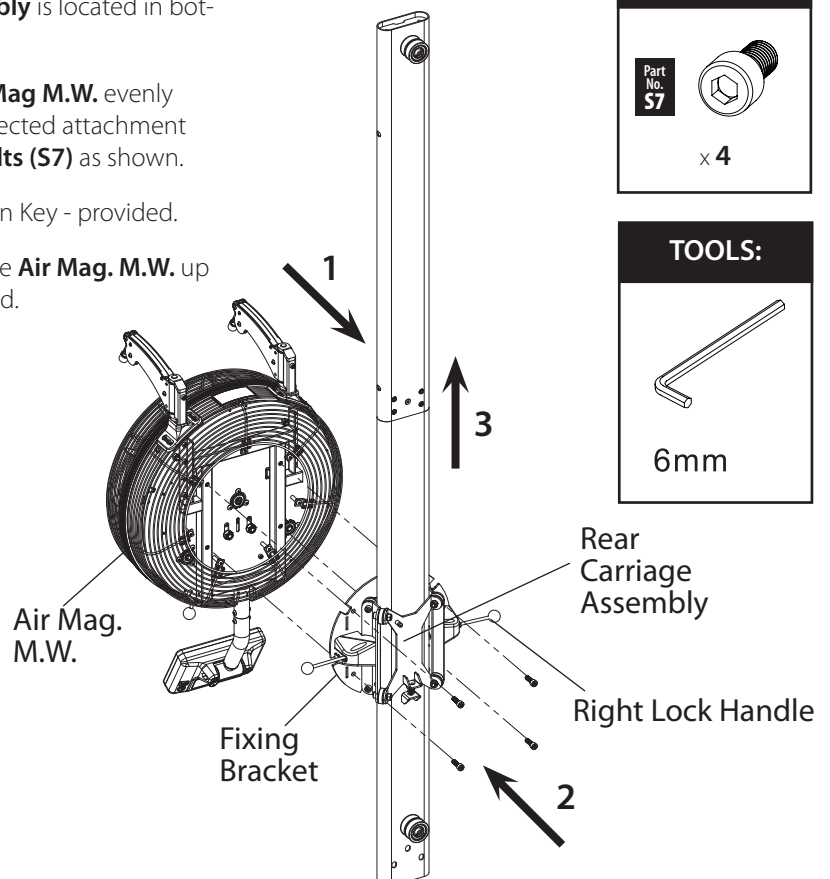

FIXINGS:



x 4

TOOLS:

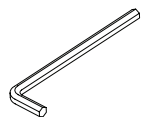

6mm

5. Attach the Elastic Cord Assembly

1. Attach one **End Metal Hook** of the **Elastic Cord (B1)** to the **Fixing Hook** welded on the **Rear Carriage Assembly** properly.
2. Wrap the **Elastic Cord** over the **inner Top Pulley Roller** and route the **Elastic Cord** as diagrams shown.
3. Wrap the **Elastic Cord** over the **inner Bottom Pulley Roller** and route the **Elastic Cord** as diagrams shown.
4. Wrap the **Elastic Cord** over the **outer Top Pulley Roller** and route the **Elastic Cord** as diagrams shown.
5. Wrap the **Elastic Cord** over the **outer Bottom Pulley Roller** and route the **Elastic Cord** as diagrams shown.
6. Attach the **End Metal Hook** of the **Elastic Cord** to the **Fixing Hook** welded on the **Top Fixing Plate (D5)** properly as shown.

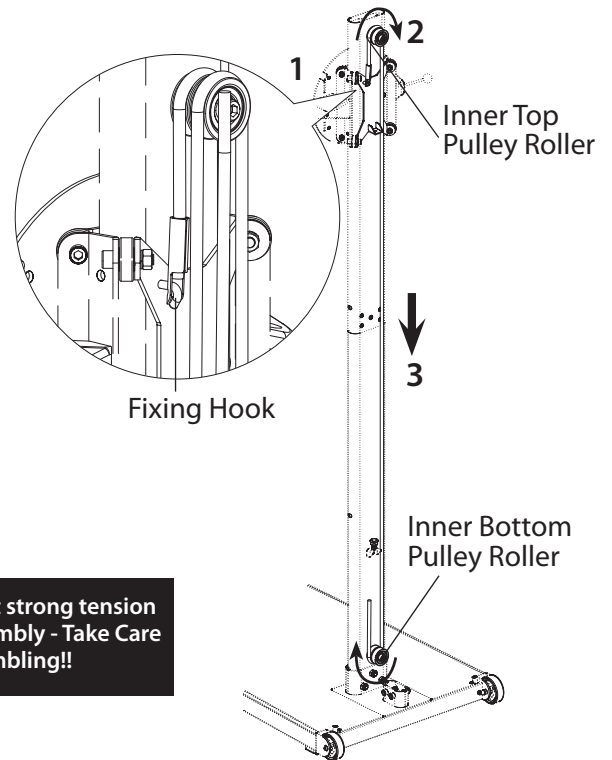

Use one hand (left) to stretch and hold the Elastic Cord firstly and use the other hand to pull the rest Elastic Cord to reach the hook on the Top Fixing Plate.

The Elastic Cord got strong tension after complete assembly - Take Care while assembling!!

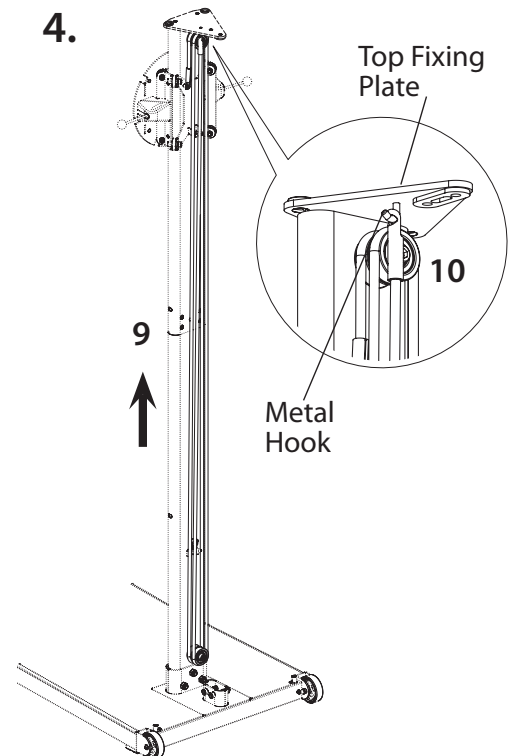
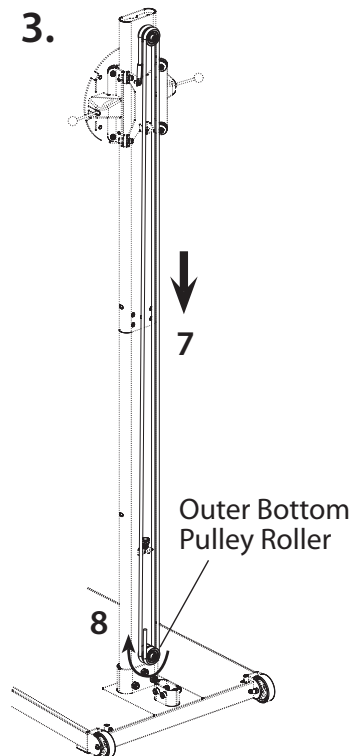
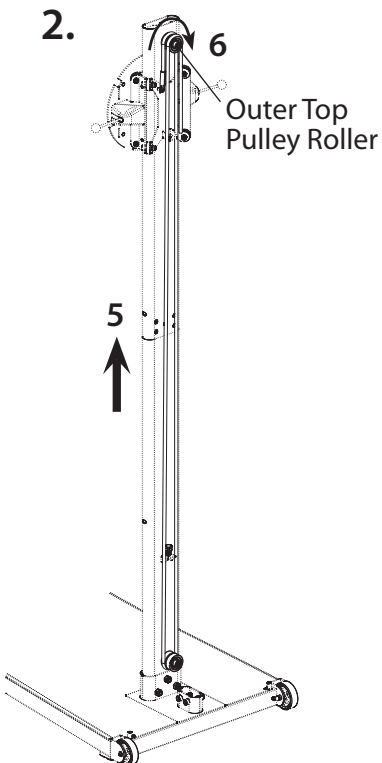

Final Checks

Your Air Mag M.W. III is now assembled. Please make the following checks before you use it for the first time.

- Make sure all screws, bolts & nuts are tighten securely.
- Make sure you have positioned it on flat & level surface.

How to Take Care of Your Air Mag. M.W. III

Storage

Keep the equipment in a dry place with as little temperature variation as possible. Try to protect from dust and always unplug when not in use (if applicable).

Cleaning & Maintenance

Your Air Mag M.W. is designed for indoor skiing used only and should not be used or stored in damp area. Ensure you regularly check components for wear and make sure all the nuts & bolts are tightened before each exercise session.

Pulling Cords – Clean daily before use.

- Check for nicks or cuts and fraying that may weaken the pulling cords' integrity even though it is made of superior quality Tetoron webbing fabric to make it extremely strong.
- Also check if the bushing at the handle end is intact. Use a warm, damp cloth to clean the whole surface of the pulling cords after every exercise if possible.

Check and Replace the Console AA Battery – Approximately every 200 hours if equipped.

Check for loose Console Arm – Approximately every month.

Clean for Dusts on Fan Wheel Assembly – Approximately every month.

Rear Carriage Rollers – Clean daily before use.

- These rollers (bearings) smooth moving will be affected by dust & dirt, so should be check and clean regularly before use if possible.
- Use a warm, damp cloth to clean the roller contact area with mild detergent if required.
- Please lubricate the roller contact surface by applying slight of the " multi-purpose grease " if necessary.

Upright Post – Clean & check daily after use.

- Use a warm, damp cloth or non-abrasive pad to clean the surface with mild detergent if required.
- Pay special attention on the both outside areas – remove any spots or dirt on it.
- Please lubricate the rollers' contact surface by applying slight of the " multi-purpose grease " if necessary.



Never remove the protective casing.



Discontinue use immediately and contact your dealer for replacement if any of the symptoms are found.

Troubleshooting



If you have a problem with your equipment, before you do anything else please check that all the cables have been connected correctly. Loose cables are very common and many problems can be solved by making sure the cables are properly connected

If you are having problems with your heart rate reading please note that some fibres used in clothes eg) polyester, create static electricity that may prevent a reliable heart rate reading. Mobile phones, TV's, microwaves and other electrical appliances that generate an electromagnetic field may also interfere with heart rate measurement.

If you are still having problems with your equipment, please get in touch with your local distributor using the details found in the Customer Support section on page 4.

Air Mag. M.W. III Features Explained

Exchanging the Grip Handle

1. Use your thumb & index finger of one hand to grasp & pull the locking sleeve as shown.
2. Attach the plug head of selected handle into the locking socket and release to secure the handle attachment properly.
3. Repeat the other side handle with same procedures

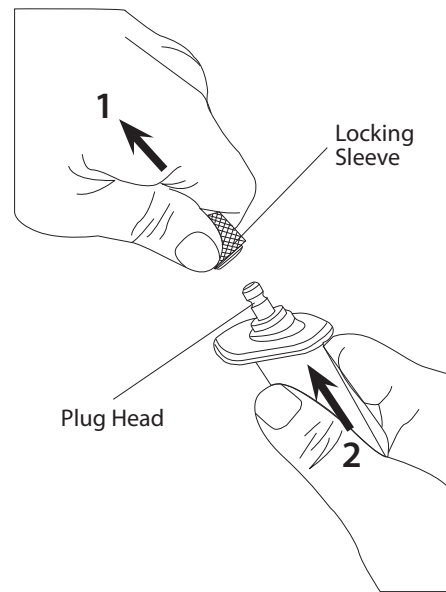

Adjusting the Console

1. Adjust the console display to suitable angle for easy viewing by rotating the console itself with both hands evenly as shown.

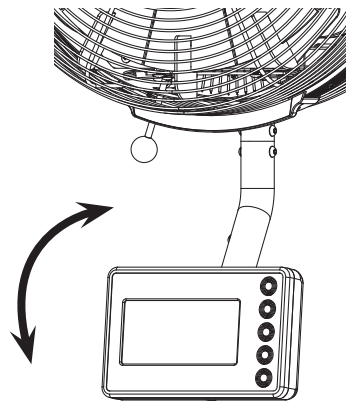

2. You can also change the console up side down for easy viewing when needed by rotating the console with both hands evenly as shown .

- Fold down or upward the displayed screen slowly.
- Rotate the console clockwise (or anti-clockwise) carefully.
- Fold up or downward the displayed screen slowly as required.

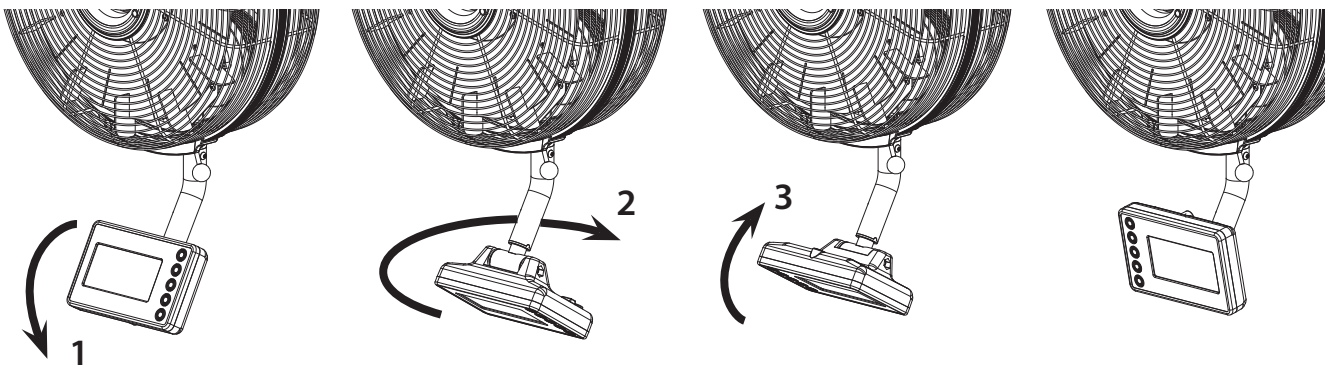

Adjusting the Resistance

1. This Air Mag M.W. features a speed independent (14 levels adjustable) system.
2. The harder you pull, the more resistance you will feel. As you put more efforts into your pulling, you will go faster, produce more watts and burn more calories. But it is more important to ski for a longer time than to ski harder.
3. The resistance is controlled by a magnet mechanism, which is moved closer or further away from the air fan wheel assembly – the closer the magnet is to the fan wheel the harder of resistance occurred.
4. The magnet is controlled manually, by moving the dial lever.
5. The resistance levels goes from 1 = easy to 14 = hard.

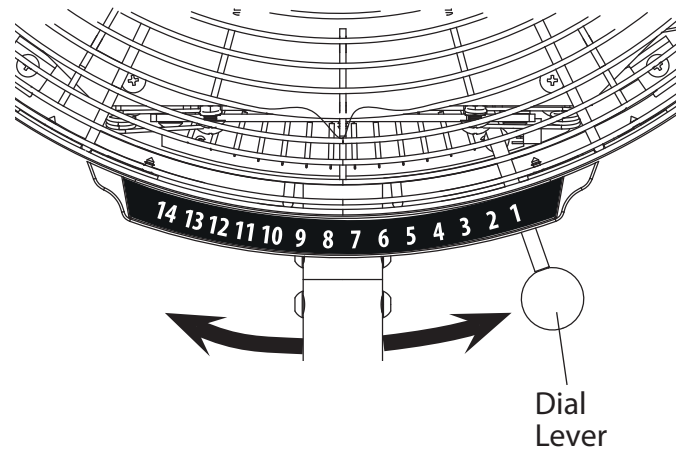

Adjusting the Locations (702011 & 702021 models)

1. Push to lift the Air Mag M.W. slightly with both hands to remove the lock pin in position
2. Pull the right side lock handle with your right hand and adjust the Air Mag M.W. up or down on the track as wished.
3. Release the right side lock handle after the required position found.

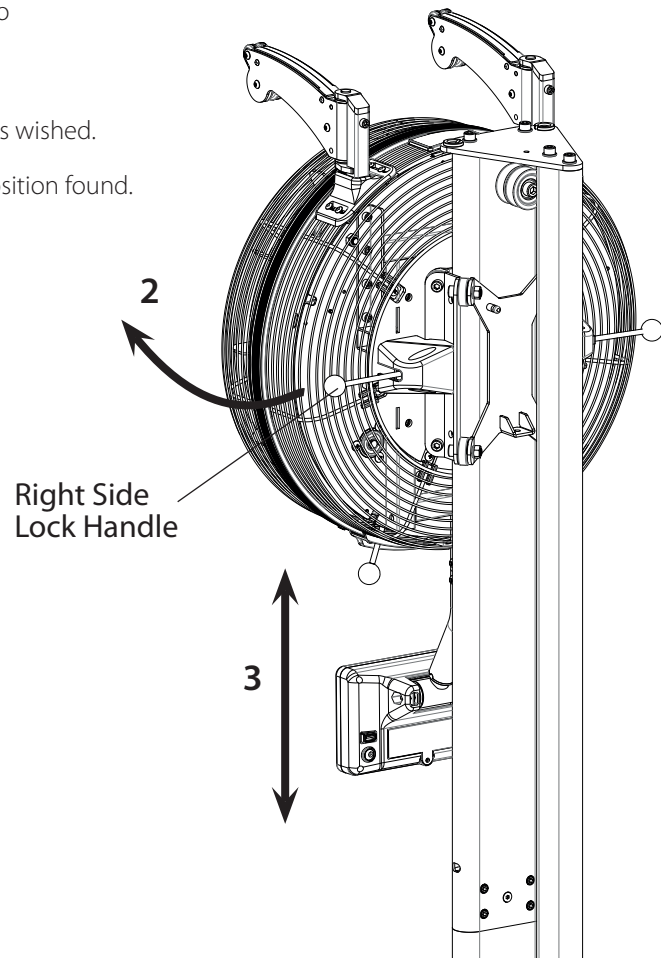

Rotating the Air Mag. M.W. (702011 & 702021 models)

1. Upside down –

- Pull the left side lock handle with your left hand and rotate the Air Mag. M.W. clockwise carefully until the stop pin engaged in position securely.

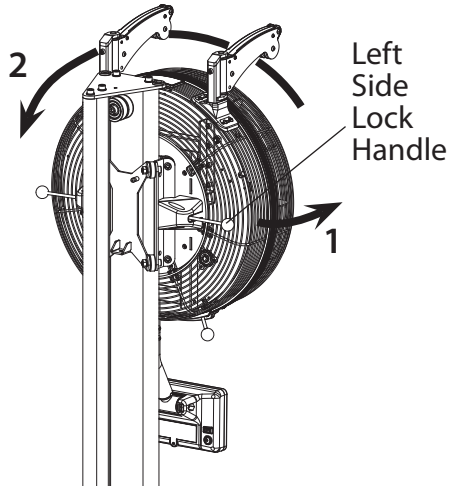

2. Back to Standard –

- Pull the left side lock handle with your left hand and rotate the Air Mag. M.W. anti-clockwise carefully until the stop pin engaged in position securely.

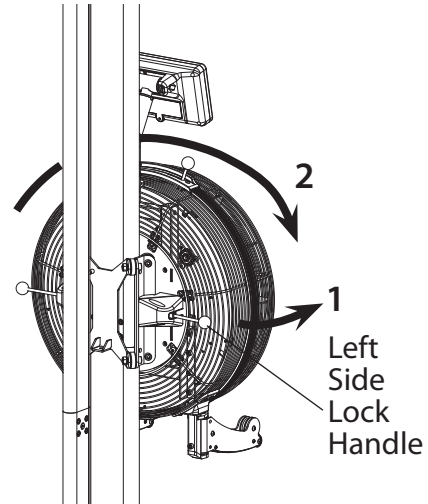

Levelling your Air Mag. M.W. III (702021 model)

1. To help you level the Air Mag. M.W.III on uneven surface, there are two height adjusters attached on the rear corners of the platform.
2. Simply turn the adjustable bolt with 5mm Allen Key – provided to adjust the height of your AirMag. M.W. III as required.

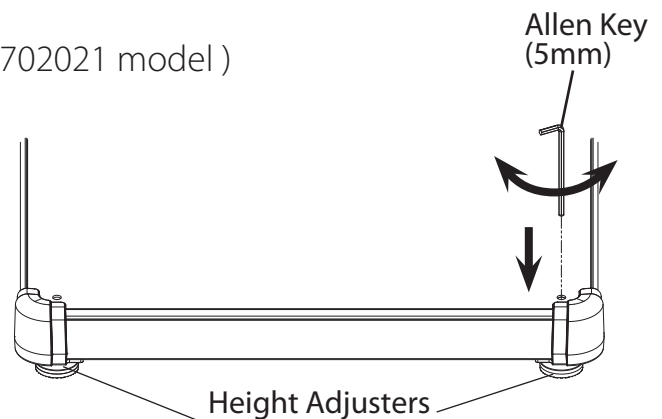

Transporting your Air Mag. M.W. III (702021 model)

1. Your Air Mag. M.W. has 2 transport wheels on the front end of the platform.
2. Stand yourself behind the Air Mag. M.W. III comfortably and hold the rear upright post with hands firmly.
3. Use your foot to stop the front end of platform while pulling down the rear upright post to raise the platform and then push to move it around.

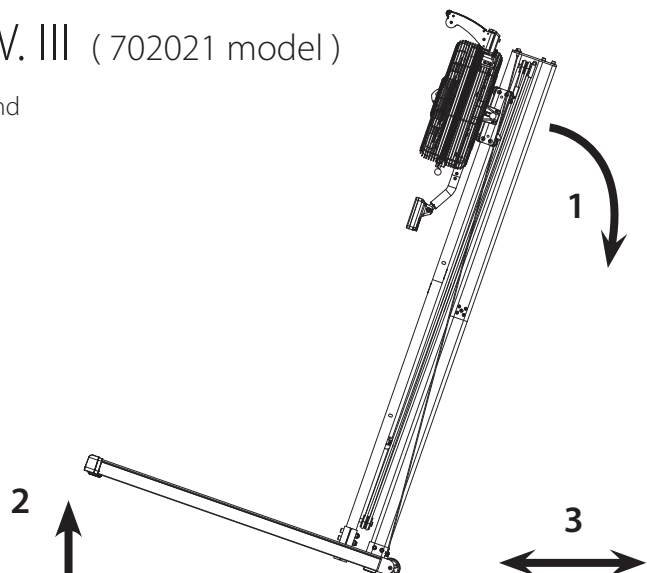

Exercising with Your Air Mag. M.W. III

Before Exercising Check:

- You have to find an adequate space ie. at least 2ft (60cm) clearance on each side.
- Check all bolts and locking pins are secured and protruding. In particular check all the bolts and pins for wear, replace doubtful parts before using the equipment.
- Always use your Air Mag. M.W. on a flat level solid surface.
- Always work within your exercise level, do not work to exhaustion.
- If you feel pain or unwell **STOP YOUR WORKOUT IMMEDIATELY.**
- Injuries may result from incorrect or excessive training.
- Please make sure you have read the safety guideline.
- Consult your physician to be sure it is not dangerous for you to undertake a strenuous exercise program.
- Do not twist or cross cords, and avoid pulling cords all the way out to the point at which they stop.
- Always pull with both handles at the same time. But you can also pull with one handle for alternating arms - classic skiing technique as well.
- Do not release handles when they are in the pulled out position. Bring handles back to the top position before releasing them.
- The wall-mounted Air Mag. M.W. must be securely fixed to the wall at the top and bottom brackets. Be sure that your mounting bolts are going into a solid material such as wood or concrete, and that you are using the proper hardware for the wall material.
- Perform regular inspection and maintenance as recommended.
- Skiing is an extremely effective form of exercise. It strengthens the heart, improves metabolism, as well as exercising all the major muscle groups - back, waist, arms, shoulders, hips & legs.
- This M.W. machine offers terrific exercise for the entire body. Each pull engages the legs, arms, shoulders and core in a downwards "crunch" using body weight to help accelerate the handles. Each pull finishes by extending the arms down along the hips with knees partly bent.
- This M.W. machine enables you to train using the motion that is essential to all techniques of skate and classic skiing.
- Check your **Proper Skiing Techniques** as below:

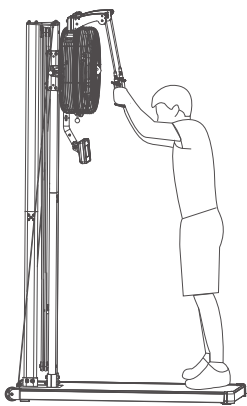

START

Begin with your hands and shoulder-width apart slightly above your head. Your arms should be bent. Your feet should be shoulder-width apart.

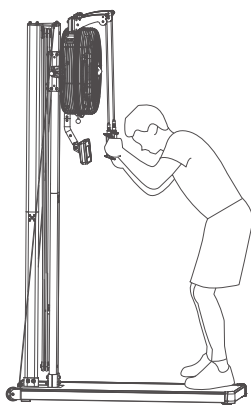

PULLING

Drive the handles downward by engaging your core abdominal muscles and bending your knees. Maintain the bend in your arms to keep the handles fairly close to your face.

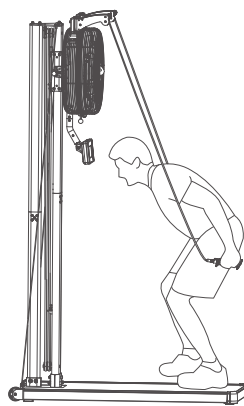

FINISH

Finish the drive with knees slightly bent, and arms extended down alongside your thighs.

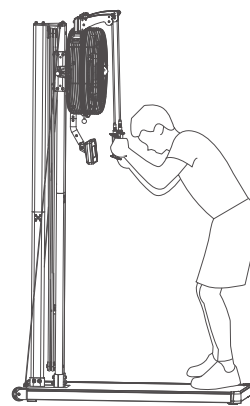

RETURN

Bring your arms back up and straighten your legs.

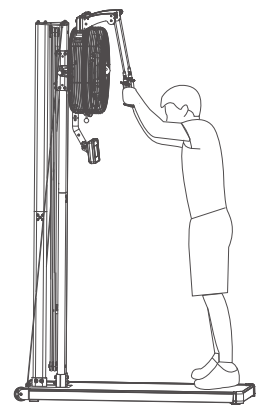

REPEAT

Extend your arms upward and straighten your body to return to the start position.

NOTE:

- Have someone watching you to help you matching your body positions as the pictures shown above.
- These positions should be blended together to make a smooth and continuous stroke with no stopping at any points in the stroke.
- Your handle grip should be grasped and comfortable and your wrist should be free during the skiing.

Start Your First SkiErg Workout:

1. Begin with a minute or two of easy skiing to learn the technique.
2. Follow the technique steps and keep the stroke rate between 25 and 30 spm.(or slower if you prefer).
3. Ski steadily and easily for 3 minutes at a stroke rate between 30 and 35 spm. Continue to practice good technique while also settling into a comfortable rhythm. Watch the console, which will show you how hard you are pulling on each stroke, how many meters (or watts or calories) you have skied, how long you have been skiing, your cadence, and your heart rate if you are connected via a HR monitor.
4. Rest for several minutes and review the console instructions, walk or stretch.
5. Ski easily again for 3-5 minutes. Depending on your comfort, your cadence may be anywhere between 30 and 45 spm.
6. Rest again for 1-2 minutes.
7. Repeat Step 5 for two or three times.

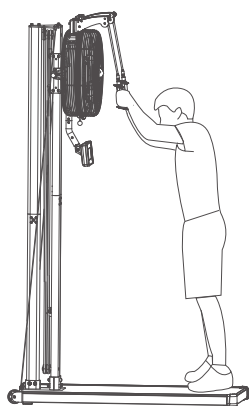

START

Begin with your hands and shoulder-width apart slightly above your head. Your arms should be bent. Your feet should be shoulder-width apart.

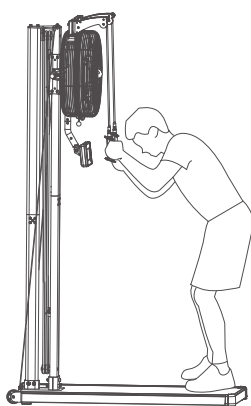

PULLING

Drive the handles downward by engaging your core abdominal muscles and bending your knees. Maintain the bend in your arms to keep the handles fairly close to your face.

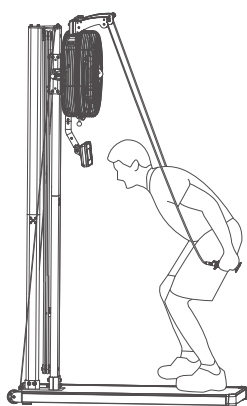

FINISH

Finish the drive with knees slightly bent, and arms extended down alongside your thighs.

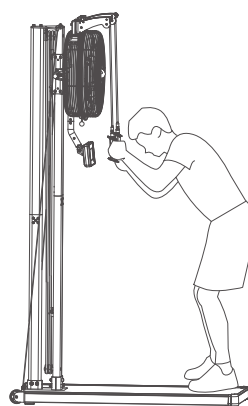

RETURN

Bring your arms back up and straighten your legs.

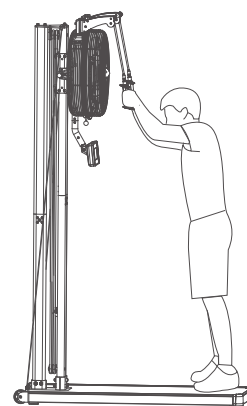

REPEAT

Extend your arms upward and straighten your body to return to the start position.

NOTE:

- Include some stretching in your exercise routine. A variety of aches and pains can be eased or prevented by investing a little time in stretching without bouncing gently.
- Gradually increase your skiing time and intensity over the first two weeks.
- Do not ski at full power until you are comfortable with the technique and have skied for at least a week. If you have not skied in over a week, take it easy for your first ski.
- Like any physical activity, if you increase the volume and intensity too rapidly, fail to warm up properly, or use poor technique, you will increase the risk of injury.
- Don't expect to be able to jump right on where you left off and don't try to do intense interval work. Start with a steady ski at a comfortable pace and try building the intensity gradually through several interval of 3-5 minutes in length from next ski.
- Lower intensity levels feel like skiing in faster snow condition, on flat terrain and downhill.
- Higher intensity levels feel more like skiing in slow condition or uphill.
- Use a intensity level setting on 8. The best, all-purpose intensity setting for a great cardiovascular workout is in the setting range of 6-10.
- Skiing with the intensity setting too high can be detrimental to your training program by reducing your output and increasing your risk of injury.
- The lower intensity setting requires you to be a little faster in applying your power which, in the end, gives you a better workout.
- Aim for a stroke rate / SPM of between 30-40 spm for general fitness.
- Your SPM can probably be lower for long steady workouts, and higher for short intense work intervals. You may vary your SPM to match your poling tempo for the range of conditions that occur on snow
- Allow a little extra time for warm-up and start very easily.
- It is important to give your body a rest every so often, even though skiing makes you feel great and you want to do it every day. We recommend taking at least one day off per week from skiing and it will make you more eager and have a better workout next day.

This Air Mag. M.W. is not only for skiers workout but also designed for other great various functions while different positions located as shown below.

High Position Located w/ Cross Grip Handles

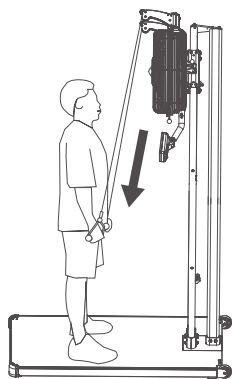

Standing Lat Pushdown

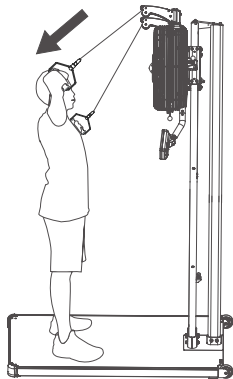

Reverse Crossover

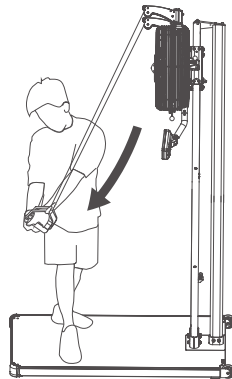

Wood Chop

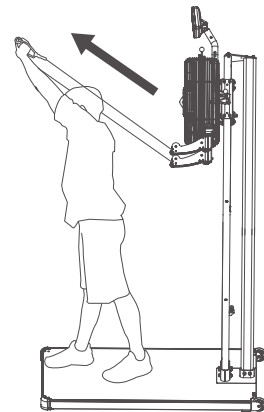

Tricep Extension (Overhead)

Middle Position Located w/ Cross Grip Handles

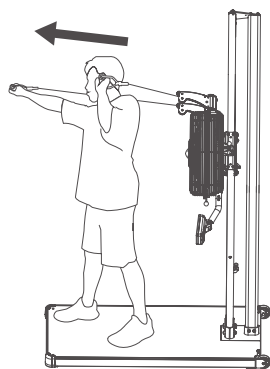

Boxing Cardio

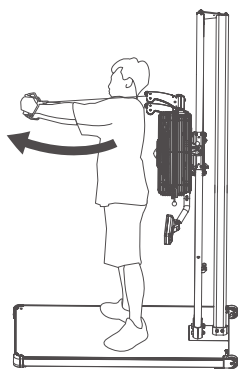

Cable Crossover

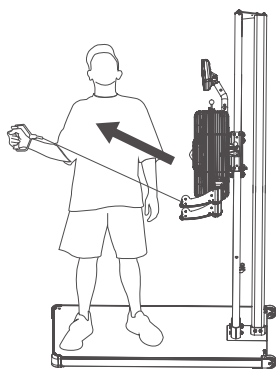

External Rotation

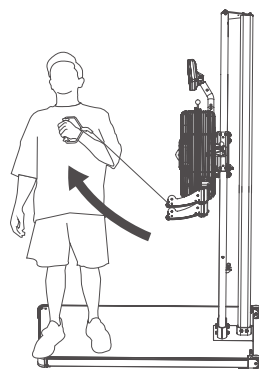

Internal Rotation

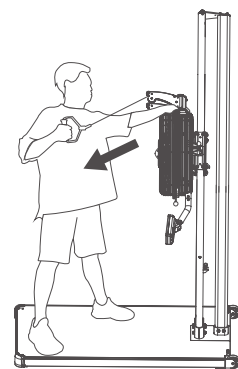

Cable Row

Low Position Located w/ Cross Grip Handles

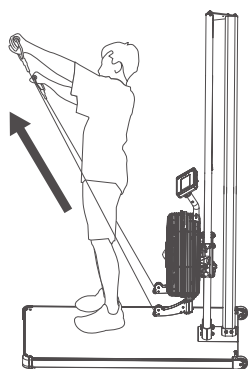

Front Delt Raise

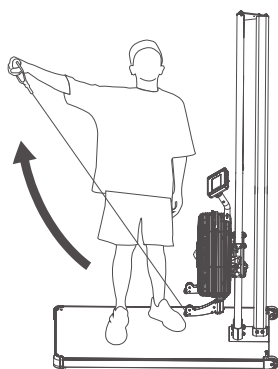

Mid Delt Raise

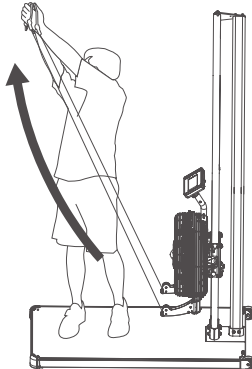

Reverse Wood Chop

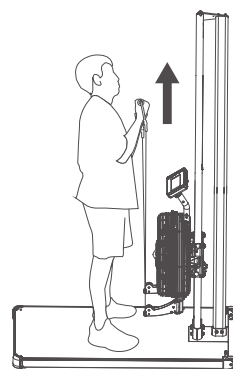

Bicep Curl

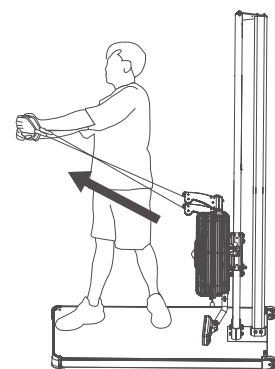

Torso Twist

Fitness

Many things contribute to fitness and well being but the most important factor is the condition of your heart and lungs and how efficient they are in delivering oxygen via your blood to your muscles. Your muscle use this oxygen to provide enough energy for daily activity. This is called aerobic activity (with oxygen).

When you are fit your heart and lungs work well and efficiently. This means your heart will not have to work so hard. It will pump a lot fewer times per minute so reducing the wear and tear on your heart. This in turn reduces the chances of your suffering heart disease.

Fitness also helps you control your weight and reduces the effects of aging and stress.

You come across the need for fitness continually in everyday life. When you are fit you can walk briskly up hills and stairs without being too out of breath once at the top you recover quickly.

As you can see there are great advantages in being fit.

How to improve your fitness

Like any muscle in your body your heart can be strengthened by systematic physical exercise which requires an increased blood flow and heart rate.

You can measure your heart rate by taking a pulse reading.

Your heart of pulse rate corresponds directly to your exertion level and exercise efficiency.

To improve your fitness in a safe and effective way you need to exercise at a high enough level to improve your aerobic fitness.

The area between these 2 levels is called the **target zone**.

It is important to exercise at the right intensity to stay within this zone.

For the best results you should exercise within the target zone and gradually increase the duration.

Ideally you should aim to exercise (within zone) for at least 15-20 minute continuously, 3-4 times per week.

Caution

Do not try to do too much to quickly start gradually and build up.

If you become ill, if you are under doctor care, or over 35-40 and not currently taking regular exercise then we would advise you not to start to exercise without consulting your doctor.

Class A test parameters

Spm	Level	Watt
25	1	24
25	7	25
25	8	26
25	14	36
35	14	68

Stroke=0.792m

Target Zone

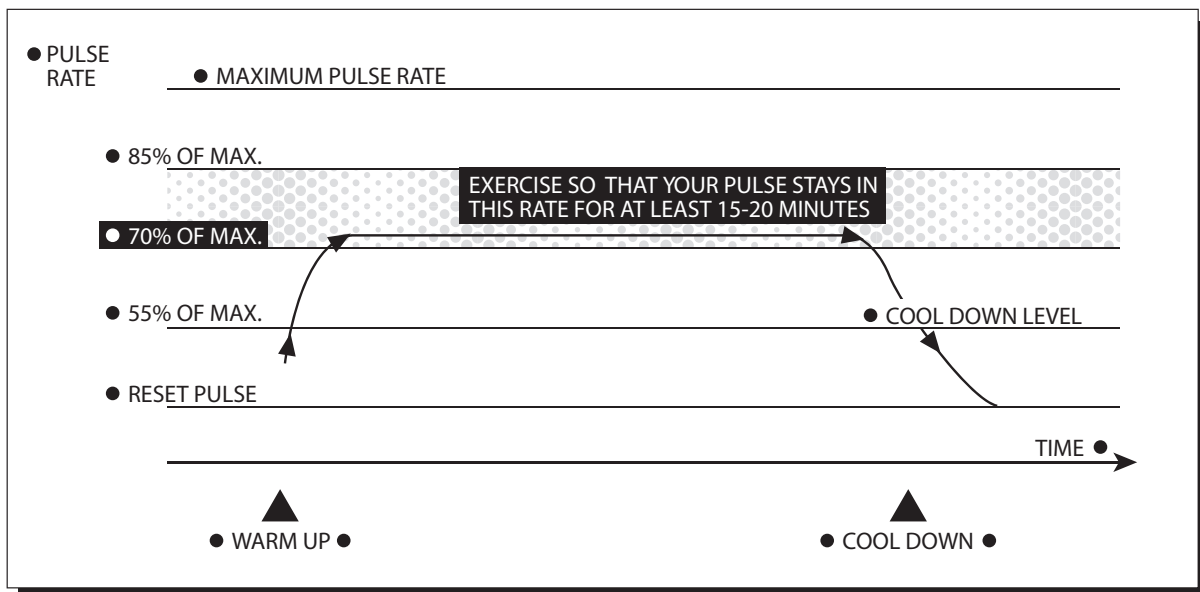

THIS IS HOW YOUR PULSE SHOULD BEHAVE DURING GENERAL FITNESS EXERCISE. REMEMBER TO WARM UP AND COOL DOWN FOR A FEW MINUTES.

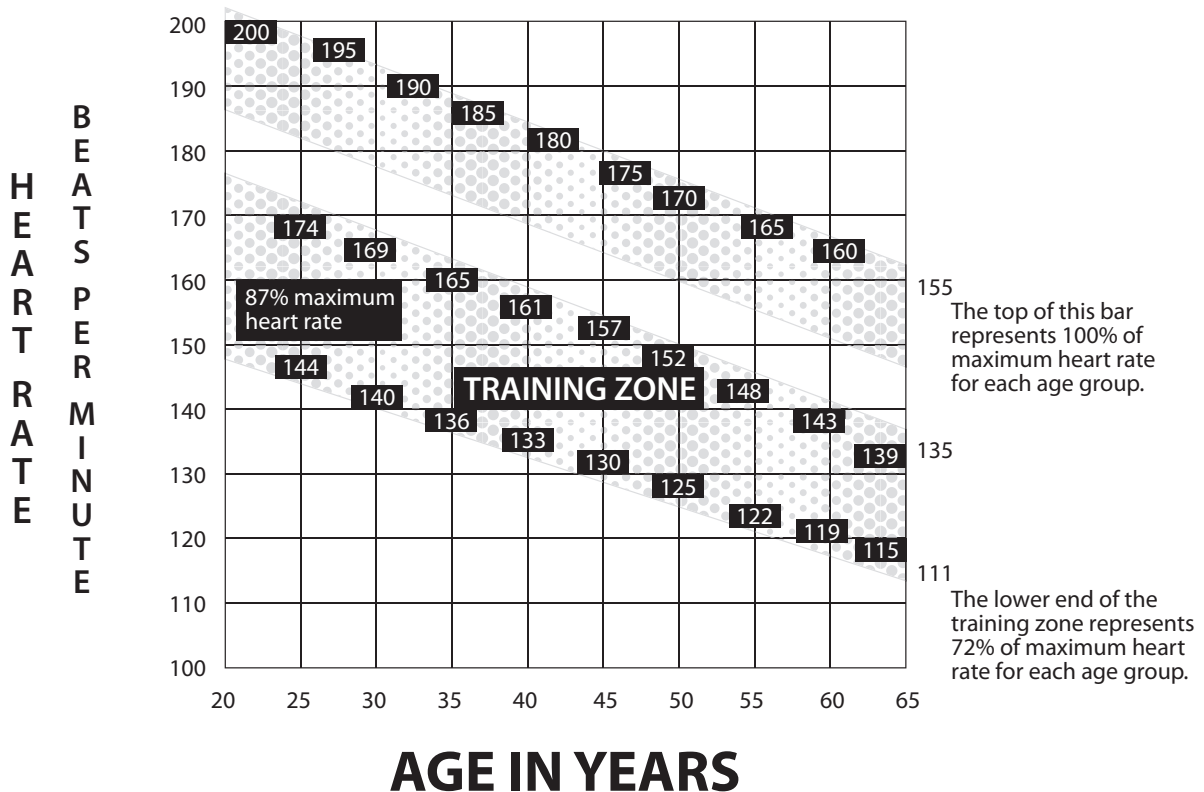

FIND YOUR OWN EXERCISE PULSE RATE RANGE BY MOVING UP THE VERTICAL LINE FOR YOUR AGE.

Example: Age 40, the vertical line meets the 70% level at about 128 and the 85% level at about 154, pulse rate should remain between these values. Use this graph to determine your personal target zone.



Always consult your doctor before undertaking a new exercise regime

If you experience nausea, dizziness or other abnormal symptoms during exercise, stop at once and consult your doctor

Starting and finishing your workout

Begin and end each workout with a Warm Up / Cool Down session – a few minutes of stretching to help prevent strains, pulls and cramps

Correct skiing form

- Begin with your hands shoulder-width apart and slightly above your head. Your arms should be bent. Your feet should be shoulder-width apart.
- Drive the handles downward by engaging your core abdominal muscles and bending your knees. Maintain the bend in your arms to keep the handles fairly close to your face.
- Finish the drive with knees slightly bent, and arms extended down alongside your thighs.
- Bring your arms back up and straighten your legs.
- Extend your arms upward and straighten your body to return to the start position.

How long should I exercise for?

That really depends on your current level of fitness. If you're just starting out on a new exercise program, you should start gradually and build up – do not try to do too much too quickly. 30 minutes, 3 times a week should be enough.

Don't push yourself too hard - you should never feel exhausted during or following exercise.

Heart Rate Training

To get the most out of your new piece of fitness equipment and see the best results from your training you should exercise at the right level of effort, and that means listening to your heart! Working out to a target heart rate means you can direct your workout to achieve different goals:

Good health - For those wishing to improve quality of life and general well being. Your sessions will need to be done at an intensity of between 50-60% of your estimated maximum heart rate, should last about 30 minutes and can be done on most days of the week.

Weight loss – To see a significant reduction in body fat, your sessions must be a little more intense - between 60 and 70% of your estimated maximum heart rate. These sessions can also be performed on most days of the week for up to 30 minutes.

Improving Fitness levels –These sessions should be performed at 70-80% of your estimated maximum heart rate and can also involve bouts of interval training that would have your heart rate peaking for short times near your maximum heart rate level. These are intense sessions and will require at least a 48 hour rest between sessions.

Calculating your target heart rate

First, you need to find your estimated maximum heart rate using the formula '220 minus your age in years'. So, if you are 35 years old your estimated maximum heart rate is:

$$220 - 35 = 185 \text{ beats per minute (bpm)}$$

Next, to calculate your target heart rate, simply multiply your estimated maximum heart rate (185 bpm) by the applicable percentage. So, if your goal is better health:

$$185 \times 60\% = 111 \text{ bpm}$$

NOTE: The important issue to remember with all estimated calculations is that they are just estimates – if you don't feel comfortable exercising at your target then reduce it to a level you are comfortable with.

Note: Heart rate training requires you to monitor your heart rate throughout the workout. For this we recommend using a chest strap (if your machine has a wireless receiver) or a heart rate monitor.

Exploded Diagram

Rear Carriage Assembly

Front Section View

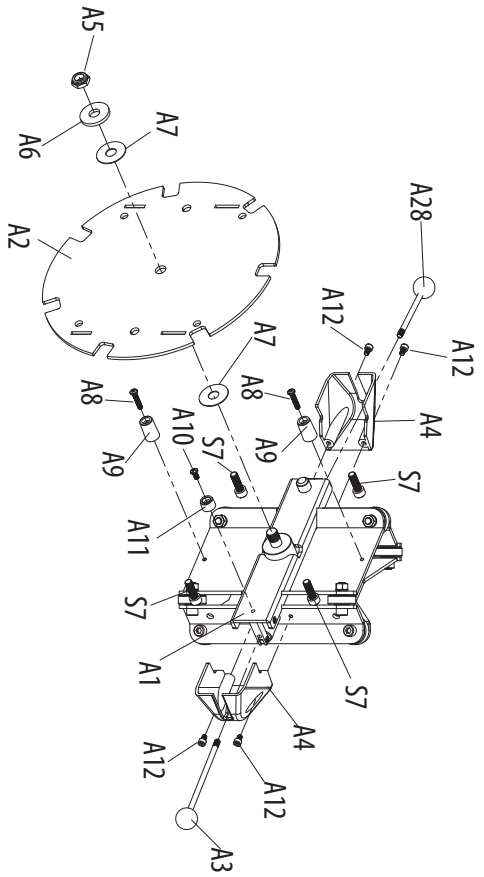

Rear Section View

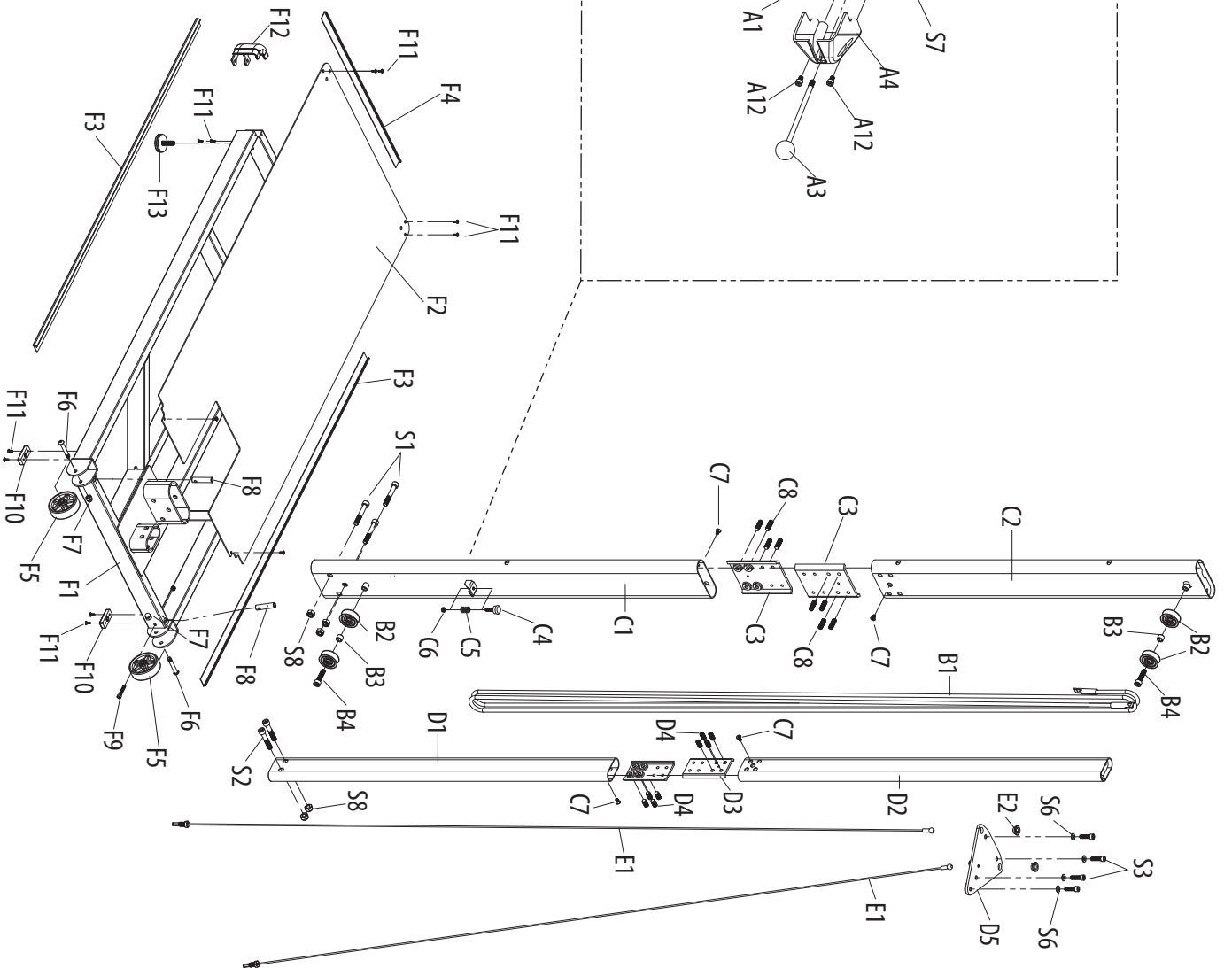
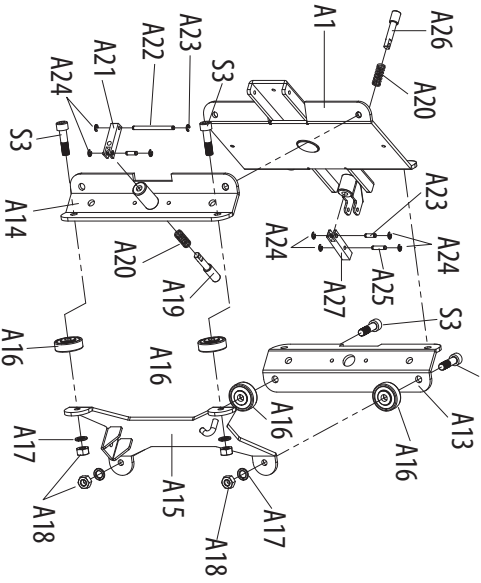

Parts List

P / N	DESCRIPTION	Q"TY
702021-A1	Rear Carriage Weldment	1
702021-A2	Fixing Bracket Plate	1
702021-A3	Right Lock Handle - OD6 x 128mm	1
702021-A4	Lock Handle Cover	2
702021-A5	1/ 2 " x 8t Hex Head Locknut	1
702021-A6	OD35 x ID13 x 4mm Metal Washer	1
702021-A7	OD35 x ID12.8 x 1mm Steel Washer	2
702021-A8	M5 x 25mm Phillip Head Machine Screw	2
702021-A9	Plastic Spacer - OD15 x ID5 x 26mm	2
702021-A10	M5 x 10mm Phillip Head Machine Screw	1
702021-A11	Plastic Spacer - OD16 x ID6 x 10.8mm	1
702021-A12	M5 x 8mm Hex Socket Head Bolt	4
702021-A13	Left Side Carriage Stamping Plate	1
702021-A14	Right Side Carriage Stamping Plate	1
702021-A15	Rear Side Carriage Stamping Plate	1
702021-A16	Metal Carriage Roller Assembly	8
702021-A17	M8 Spring Washer	8
702021-A18	M8 Hex Head Locknut	8
702021-A19	OD10 x 54mm Stop Pin	1
702021-A20	OD7.5 x 9.5mm x 1mm Metal Spring	2
702021-A21	Right side SQ Metal Block- SQ9.5 x 40.5mm	1
702021-A22	OD4 x 54mm Metal Shaft	1
702021-A23	OD4 x 13.4mm Metal Shaft	2
702021-A24	E- Clip (E3)	8
702021-A25	OD4 x 17.4mm Metal Shaft	1
702021-A26	OD10 x 47mm Stop Pin	1
702021-A27	Left Side SQ Metal Block - SQ 9.5 x 46 mm	1
702021-A28	Left Lock Handle - OD6 x 92mm	1
702021-B1	Elastic Cord w / End Hooks attached	1
702021-B2	Plastic Pulley Roller	4
702021-B3	Metal Spacer - OD15 x ID10 x 2mm	2
702021-B4	M10 x 40mm Hex Socket Head Bolt	2
702021-C1	Bottom Section Main Stem	1
702021-C2	Top Section Main Stem	1
702021-C3	Metal Connected Plate	2
702021-C4	Rubber End Stop	1
702021-C5	Metal Spring - OD14.5 x 20mm x 2mm	1
702021-C6	M6 Hex Head Locknut	1
702021-C7	M6 x 12mm Countersunk Head Socket Screw	4
702021-C8	M10 x 35mm Socket Set Screw	8
702021-D1	Bottom Section Rear Upright Post	1
702021-D2	Top Section Rear Upright Post	1
702021-D3	Metal Connected Plate	2
702021-D4	M10 x 25mm Socket Set Screw	8
702021-D5	Top Fixing Plate	1
702021-E1	Side Cable Wire w/ End Ball & Bolt	2
702021-E2	Metal Spring Spacer	2
702021-F1	Platform main frame	1
702021-F2	Platform Standing Plate	1
702021-F3	Plastic Panel - side - 1150mm	2
702021-F4	Plastic Panel - front - 524mm	1
702021-F5	Moving Wheel	2
702021-F6	M8 x 50mm Allen Head Bolt	2
702021-F7	M8 Cap Locknut	2
702021-F8	Metal Sleeve - OD12.7 x 52mm	2
702021-F9	M6 x 35mm Hex Socket Head Bolt	2
702021-F10	Stop Pad - 50mm x 20mm x 10.5mm	2
702021-F11	M4 x 12mm Selt Tapping Screw	14
702021-F12	Plastic Corner Cover	2
702021-F13	Height Adjuster	2
702021-S1	M10 x 65mm Hex Socket Head Bolt	3
702021-S2	M10 x 55mm Hex Socket Head Bolt	2
702021-S3	M8 x 30mm Hex Socket Head Bolt	12
702021-S6	8mm x 16mm x 2mm Washer	4
702021-S7	M8 x 25mm Hex Socket Head Bolt	4
702021-S8	M10 Hex Head Locknut	5

Your Warranty

This product is supplied with a 1 year warranty as follows:

This product is warranted for use in a commercial environment

This warranty excludes damage to the finish of the machine, damage sustained as a result of neglect, abuse, or failure to follow the suggested maintenance requirements (see Maintenance), shipping charges and if applicable, labor for the installation of any parts shipped to the owner under this warranty.

Please Note: Warranty details may vary from one market area to another

Warranty Terms

We warrant that the Product you have purchased from an authorised reseller is free from defects in materials and workmanship. The Warranty is valid subject to normal and reasonable use in the environment as described above, and correct assembly of the product during the warranty period. The warranty period extends to the original purchaser only. It is not transferable to anyone who subsequently purchases the Product from you.

The warranty excludes normal wear and tear on parts.

Your sales receipt, showing the date of purchase of the product, is your proof of the date of purchase.

This warranty becomes valid only if the Product is assembled / installed according to the instructions / directions included with the product. This warranty does not extend to any product that has been damaged or rendered defective: (a) as a result of accident, misuse, abuse or lack of reasonable care; (b) by the use of parts not manufactured by us or sold by us by modification of the product; (c) as a result of service by anyone else other than us or an authorised warranty service provider.

During the warranty period we will at no additional charge provide replacement part(s) or repair the product (at our option) if it becomes defective, malfunctions or otherwise fails to conform with this warranty under normal, non-commercial, personal, family or household use. In repairing the product, we may replace defective parts or at the option of ours, use serviceable used parts that are equivalent to new parts in performance. All exchanged parts and products replaced under this warranty will become the property of ours. We reserves the right to change manufacturers of any part to cover any existing warranty.

If the product must be returned, you must return the Product or defective part to us in its original container (or equivalent) with Proof of Purchase. Any evidence of alteration, erasing or forgery of proof of purchase documents will be cause to void this warranty. You must prepay any shipping charges and you are responsible for insuring any product or part that is returned. Should any product submitted for warranty service be found to be ineligible, an estimate of repair cost will be furnished and the repair will be made if requested, upon our receipt of payment or acceptable arrangement of payment. Under no circumstances will returns be accepted without return authorisation by our Customer Service department.

To obtain warranty service you must and provide the following information:

Name of Product, Product Code, Batch No, Date Purchased, and Nature of fault or part number required.

Neither dealer of this product nor any retail establishment selling this product has any authority to make any warranties or to promise remedies in addition to, or inconsistent with, those stated above. This warranty does not affect your statutory rights.

Please note that warranty terms may vary from one market area to another